

VS NetCom Serial Device Server

Cable Versions User Manual

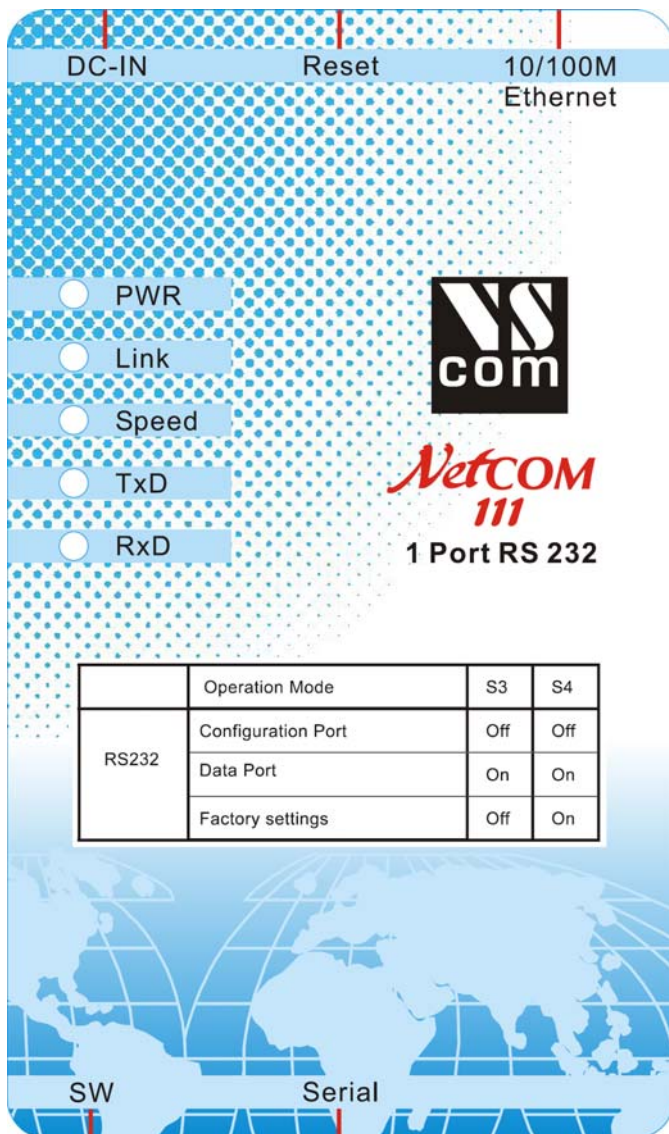

***NetCom 111, 113, 211, 411, 413, 811, 813
and 811RM, 813RM***

1. TABLES

1.1. TABLE OF CONTENTS

1. TABLES	1
1.1. TABLE OF CONTENTS.....	1
1.2. TABLE OF IMAGES.....	5
1.3. TABLE OF TABLES.....	9
2. INTRODUCTION	10
2.1. FEATURES.....	10
2.2. PRODUCT SPECIFICATIONS	11
2.2.1. Common Characteristics.....	11
2.2.2. Specific Characteristics	12
2.2.2.1. NetCom 111 and 113.....	12
2.2.2.2. NetCom 211.....	12
2.2.2.3. NetCom 411 and 413.....	13
2.2.2.4. NetCom 811 and 813.....	13
2.2.2.5. NetCom 811RM and 813RM (19" version).....	14
2.3. PACKING LIST.....	15
3. HARDWARE CONFIGURATION	16
3.1. POWER SUPPLY.....	16
3.2. ETHERNET	16
3.3. SERIAL PORT SIMPLE SETTINGS.....	17
4. WINDOWS DRIVER QUICK INSTALLATION	18
4.1. INSTALLATION PROCEDURE	18
4.1.1. Start the Installation Wizard.....	18
4.1.2. Find and configure NetCom Devices	19
4.1.2.1. Configure IP Parameters.....	20
4.1.2.2. Configure Firewall.....	20
4.1.3. Install Drivers	21
4.2. VERIFY THE INSTALLATION.....	22
4.3. UNINSTALL THE DRIVERS	24
5. SOFTWARE CONFIGURATION	25
5.1. CONFIGURE IN WEB-INTERFACE	27
5.1.1. Webbrowser Server Configuration.....	27
5.1.1.1. Server Info	28
5.1.1.2. Server Parameter.....	28

5.1.1.3.	Authentication	29
5.1.1.4.	Date & Time	29
5.1.2.	Webbrowser Serial Port Configuration	30
5.1.2.1.	Serial Settings	30
5.1.2.2.	Transfer Settings.....	31
5.1.2.2.1.	Driver Mode.....	32
5.1.2.2.2.	TCP Raw Server	32
5.1.2.2.3.	TCP Raw Client	32
5.1.2.2.4.	Null Modem Tunnel.....	33
5.1.2.2.5.	IP-Modem	34
5.1.2.2.6.	TCP Advanced Settings	34
5.1.2.2.7.	UDP Data Transfer	35
5.1.2.2.8.	Print Server Function	35
5.1.3.	Webbrowser NetCom Tools	36
5.1.3.1.	Ping.....	36
5.1.3.2.	Statistics.....	37
5.1.3.3.	Netstat.....	38
5.1.3.4.	Firmware.....	39
5.1.3.5.	Save and Load Configuration	39
5.1.3.6.	Logging and Debug	39
5.2.	CONFIGURE WITH MANAGER PROGRAM	40
5.2.1.	Starting NetCom Manager.....	41
5.2.2.	NetCom Server Settings - Info	42
5.2.3.	NetCom Server Settings - Ports.....	43
5.2.4.	NetCom Server Settings - Firewall.....	44
5.2.5.	NetCom Server Settings – Options.....	45
5.2.6.	Manual Detection/Installation of a NetCom.....	46
5.2.7.	Firewall Traversal Configuration	46
5.2.7.1.	SOHO Firewall example	46
5.2.7.2.	SOHO Virtual Servers	47
5.2.7.3.	NetCom Detection through SOHO Firewall	48
5.2.7.4.	Serial Ports through SOHO Firewall	49
5.2.7.5.	DMZ and Virtual Servers	50
5.3.	CONFIGURE NETCOM VIA TELNET CONSOLE.....	51
5.3.1.	Telnet Main Menu	52
5.3.2.	Server Configuration Menu	53
5.3.2.1.	Parameter	53
5.3.2.2.	Authentication	54
5.3.2.3.	Date & Time	54

5.3.2.4.	Info.....	55
5.3.3.	Serial Ports Menu	55
5.3.3.1.	Communication Parameters.....	55
5.3.3.2.	Data Transfer Modes	57
5.3.3.2.1.	Driver Mode.....	59
5.3.3.2.2.	TCP Raw Server Mode	59
5.3.3.2.3.	TCP Raw Client Mode.....	60
5.3.3.2.4.	Null Modem Tunnel.....	60
5.3.3.2.5.	IP Modem.....	61
5.3.3.2.6.	UDP Mode	61
5.3.3.2.7.	Print Server Function	62
5.3.4.	Tools Menu	62
5.3.4.1.	Ping.....	62
5.3.4.2.	Statistics.....	63
5.3.4.3.	Netstat.....	63
5.3.4.4.	Logging.....	64
5.3.4.5.	Firmware.....	64
5.3.5.	Save&Exit Menu	65
5.3.5.1.	Save Parameter	65
5.3.5.2.	Exit.....	65
5.3.5.3.	Reboot.....	65
5.4.	CONFIGURE NETCOM VIA SERIAL CONSOLE	66
6.	THE VIRTUAL COM DRIVER	67
6.1.	INSTALLATION OF NETCOM SERVERS.....	67
6.1.1.	Changing the Installation.....	69
6.2.	CONFIGURE THE SERIAL PORTS	70
6.3.	PERFORMANCE ISSUES.....	71
6.4.	NETWORK & MISC PROPERTIES.....	72
6.5.	REMOTE SETTINGS PROPERTIES.....	74
7.	UNINSTALLING THE SOFTWARE	76
8.	SPECIAL FUNCTIONALITIES	78
8.1.	IP MODEM FUNCTION.....	78
8.1.1.	Some Possible Scenarios:	78
8.1.2.	Serial signals and cables	79
8.1.3.	Operation Modes by IP Modem	80
8.1.4.	Hayes commands.....	80
8.1.4.1.	AT command set.....	80
8.1.4.1.1.	Standard AT-Commands.....	81

8.1.4.1.2.	Extended AT-Commands.....	81
8.1.4.1.3.	Non-AT commands.....	82
8.1.4.2.	S-Registers for Configuration.....	82
8.1.4.3.	Sample Commands used by Windows	83
8.1.5.	Description of AT-Commands	83
8.1.5.1.	AT D (dial)	83
8.1.5.2.	AT O (online / data mode).....	84
8.1.5.3.	AT A (answer call)	84
8.1.5.4.	AT B (modulation) [ATB1].....	84
8.1.5.5.	AT E (echo) [ATE1].....	84
8.1.5.6.	AT Q (quiet) [ATQ0]	84
8.1.5.7.	AT V (verbose) [ATV1].....	85
8.1.5.8.	AT H (hangup) [ATH0].....	85
8.1.5.9.	AT I(n) (information) [ATI0].....	85
8.1.5.10.	AT S (setup).....	85
8.1.5.11.	AT L (loudness).....	86
8.1.5.12.	AT M (speaker)	86
8.1.5.13.	AT N (auto baud) ATN0	86
8.1.5.14.	AT Z (reset)	86
8.1.5.15.	AT &F (factory settings) [AT&F0].....	86
8.1.5.16.	AT &C (DCD configuration) [AT&C1].....	86
8.1.5.17.	AT &S (DSR configuration) [AT&S0]	86
8.1.5.18.	AT &D (DTR configuration) [AT&D2].....	87
8.1.5.19.	AT &K (handshake) [AT&K3] AT \Q [AT\Q3]	87
8.1.5.20.	AT &V (view profile).....	87
8.1.5.21.	AT &W (save profile).....	87
8.1.5.22.	AT &Z (save destination).....	87
8.2.	PRINT SERVER OPERATION	88
8.2.1.	Printer Queue	88
8.2.2.	Printer Reset	88
8.2.2.1.	Init String Definition	89
8.2.2.1.1.	ASCII Text.....	89
8.2.2.1.2.	ASCII Control Codes.....	89
8.2.2.1.3.	Numeric Codes.....	89
8.2.2.1.4.	Modem Control Signals	89
8.2.2.1.5.	Timing Options	89
8.2.2.2.	Reset Example	90
8.2.3.	Operation in Windows®	90

8.2.3.1.	Add a New Printer	90
8.2.3.1.1.	Create new printer port	91
8.2.3.1.2.	Name the new Printer Port	92
8.2.3.1.3.	Configure the Printer Port	92
8.2.3.1.4.	Install Printer Driver	93
8.2.3.2.	Modify an Existing Printer	93
8.2.3.2.1.	Open the properties	94
8.2.3.2.2.	Add the Print Server Port	94
9.	TCP/IP DESCRIPTION	95
9.1.	RECOMMENDED SETTINGS	95
9.1.1.	Static Configuration	95
9.1.2.	DHCP Configuration	95
9.1.3.	Automatic Configuration (APIPA)	96
9.1.4.	Other Configuration	96
10.	HARDWARE DETAILS	97
10.1.	SERIAL PORT	97
10.2.	SIGNAL ASSIGNMENT	99
10.3.	VIEWS OF NETCOM	100
10.3.1.	NetCom 111, 113 and 211	100
10.3.2.	NetCom 411 and 413	101
10.3.3.	NetCom 811 and 813	102
10.3.4.	NetCom 811RM and 813RM Rackmount	103
11.	TROUBLESHOOTING GUIDE	104
12.	GLOSSARY OF TERMS	107

1.2. TABLE OF IMAGES

Installation Wizard	18
Start Driver Installation	18
Discover and Select NetCom Devices for Installation	19
Define NetComs IP Configuration	20
Use current drivers dialog	21
Install drivers for the serial ports	22
VScom drivers in the Start Menu	22
NetCom in Device Manager	23
NetCom Manager NT	23
Uninstall NetCom Drivers	24
NetCom Manager	25

NetCom Manager Servers Panel.....	26
NetCom IP-Parameters	26
Webinterface for configuration	27
Webinterface Request to Reboot	27
Web Panel Server Information	28
Web Panel Server Parameter	28
Web Panel Authentication	29
Web Panel Date & Time.....	29
Web Panel Serial Settings.....	30
Web Panel Advanced Flow Control	31
Serial Port Mode Selection	31
Web Panel Driver Mode	32
Web Panel TCP Raw Server.....	32
Web Panel Raw Client.....	32
Web Panel Null Modem Tunnel	33
Web Panel IP-Modem	34
Web Panel TCP Advanced Settings	34
Web Panel UDP Data Transfer.....	35
Web Panel Print Server Configuration	35
Web Panel Ping	36
Web Panel Statistics Port Selection.....	37
Web Panel Port Statistics.....	37
Web Panel Start Netstat.....	38
Web Panel Netstat Output	38
Web Panel Firmware Upload	39
Web Panel Save/Load Configuration	39
Web Panel Syslog & Debug	39
NetCom Manager	40
NetCom Manager in Start Menu	40
NetCom Manager in Device Manager.....	40
NetCom Manager “Servers” Panel	41
NetCom Server Settings	42
NetCom Ports Panel.....	43
NetCom Firewall Panel	44
NetCom Options Panel	45
NetCom Firewall Panel	48
Port Configuration for Driver	49
Password protected Telnet option.....	51
Open configuration menu	51

Main menu configuration console	52
Pull Down Server Configuration	53
IP-Configuration Parameters	53
Access Authentication	54
Password Dialog	54
Date & Time	54
Date and Time Retrieval options	54
Information	55
NetCom Server Information	55
Menu, select serial port for configuration	55
Config Communication Parameters.....	55
Serial transfer parameters	56
Standard Flow Controls	56
Advanced Flow Control configuration	56
Config Data Transfer Mode (TCP/IP).....	57
TCP-Ports for Driver mode and Raw Data.....	57
Available Transfer Modes	57
Parameters for transfer modes	58
Driver Mode parameters	59
TCP Raw Server parameters.....	59
TCP Raw Client parameters	60
Null Modem Tunnel parameters.....	60
IP Modem Parameters	61
UDP Mode parameters	61
Telnet Print Server Configuration	62
Tools menu	62
Ping test utility.....	62
Statistics for serial ports	63
Status and Statistics	63
Netstat analysis	63
Sample Netstat output.....	63
Syslog Option	64
Syslog configuration.....	64
Firmware Update	64
Settings, Firmware Update via TCP/IP	64
Save actual Parameters	65
Exit from configuration	65
Exit and Reboot	65
Select NetCom to install.....	67

Excluded NetCom.....	68
NetCom Manager Ports View.....	68
Reconfigured NetCom found.....	69
Replaced NetCom found	69
NetCom COM Port Serial Settings.....	70
NetCom COM Port Performance Settings.....	71
NetCom COM Port Network & Misc Properties.....	72
NetCom COM Port Remote Settings Properties	74
To uninstall the NetCom software.....	76
Uninstall in the Start Menu.....	76
Confirm Uninstall of Drivers.....	76
Installation Wizard to uninstall Drivers.....	77
Add a printer	90
Select Printer Port.....	91
Create Printer Port	91
Properties of Print Server Port.....	92
Properties of Print Server Port.....	93
Printer Port Properties	94
Add Printer Port.....	94
NetCom-111 (113) Top and Front Side.....	100
NetCom-211 Top and Front Side	100
NetCom 411/413 Top, Front and Rear Side	101
NetCom 811 and 813 Top, Front and Rear Side	102
NetCom 811RM and 813RM Top, Front and Rear Side.....	103

1.3. TABLE OF TABLES

Specifications, common.....	11
Characteristics of NetCom 111 and 113.....	12
Characteristics of NetCom 211.....	12
Characteristics of NetCom 411 and 413.....	13
Characteristics of NetCom 811 and 813.....	13
Characteristics of NetCom 811RM and 813RM.....	14
LED Function.....	16
IP Modem Standard AT-Commands.....	81
IP Modem Extended AT-Commands.....	82
IP Modem S-Registers for Configuration.....	82
Switch Configuration of NetCom 113, 413, 813 and 813RM.....	97
Switch Configuration of NetCom 111, 411, 811 and 811RM.....	98
Switch Configuration of NetCom 211.....	98
Signal Assignment DB9 female.....	99
Signal Assignment RJ45 and DB9 male cable.....	99

2. INTRODUCTION

This manual covers several different models of NetCom Devices. In general the operation is the same on all models, except where explicitly noted otherwise.

The VS NetCom devices are designed to remotely operate serial ports over networks. The network interface is 100Mbit/s Ethernet on all cable operated models. The transport is implemented via TCP/IP protocol. Therefore control is available via Ethernet, Intranet and Internet.

The supplied driver software hides the network transfer from your applications. Software applications using standard COM ports need no change to operate via NetCom through the virtual serial ports.

The devices come with a steel case well suited for industrial environments.

NetCom supports high serial speeds up to 460 kbps. All serial ports operate in common RS-232 mode. The models NetCom 113, 413, 813 and 813RM also offer the industrial RS-422 and RS-485 configuration. In RS-485 mode the NetCom may use the Automatic Receive Transmit (ART) control logic to follow the RS-485 specifications for transmitting data. No special code is necessary to be implemented in your software applications.

2.1. FEATURES

- Single power supply DC 9V-30V, 200-600 mA@12V
AC 100-240V 47-63Hz, 25VA
- Ethernet 10/100BaseTx for auto-configuration
- Three serial port interfaces: RS-232 (and RS-422/485)
- Max. 460.800 bps, half- and full-duplex
- TCP/IP configuration fixed or by DHCP
- Easy remote configuration via SNMP
- Drivers for Windows™ and Linux operating systems
- Documented interface for every networked operating system

2.2. PRODUCT SPECIFICATIONS

Most of the characteristics are common for all models. However some must differ from model to model.

2.2.1. COMMON CHARACTERISTICS

Processor	ARM7 (S3C4510B)
Memory	8MB SDRAM 1MB Flash (2MB with 8 serial ports)
Ethernet connector	RJ45 10BaseT/100BaseTx
Serial Speed	14 bps up to 460.8 kbps
Parity	None, Even, Odd, Mark, Space
Data bits	5, 6, 7, 8
Stop bits	1, 2 (1.5)
Protocols	TCP/IP, UDP, SNMP, DHCP, ICMP, ARP, Telnet, RTelnet, HTTP
Management	Serial console, Telnet, Webbrowser, SNMP
Driver software	Windows 2000/XP, Windows NT, Linux
Management software	Driver installation and configuration program, Management console
Operating temp.	0° to 55°C
Approval	CE, FCC

Table 1: Specifications, common

2.2.2.SPECIFIC CHARACTERISTICS

2.2.2.1. NetCom 111 and 113

Serial connector	DB9 female (similar to Modem)	
Serial ports	1 × RS-232 configured by DIP switch, (RS-422/485 on NetCom 113 only)	
Serial signals	RS-232	TxD, RxD, RTS, CTS, DTR, DSR, DCD, RI, GND
	RS-422, RS-485 4-wire	Tx+/Tx-, Rx+/Rx-, GND
	RS-485 2-wire	Data+/Data-, GND
Power requirement	DC 9V to 30V, 200 mA@12V	
Dimensions	73×115×27 mm ³ (W×D×H)	
	101×121×27 mm ³ with connectors	
Weight	250 g	

Table 2: Characteristics of NetCom 111 and 113

2.2.2.2. NetCom 211

Serial connector	RJ45, Adapter cable to DB9 male (like PC)	
Serial ports	2 × RS-232	
Serial signals	TxD, RxD, RTS, CTS, DTR, DSR, DCD, GND	
Power requirement	DC 9V to 30V, 300 mA@12V	
Dimensions	73×115×27 mm ³ (W×D×H)	
	101×121×27 mm ³ with connectors	
Weight	200 g	

Table 3: Characteristics of NetCom 211

2.2.2.3. NetCom 411 and 413

Serial connector	DB9 female (similar to Modem)	
Serial ports	4 × RS-232 configured by DIP switch, (RS-422/485 on NetCom 413 only)	
Serial signals	RS-232	TxD, RxD, RTS, CTS, DTR, DSR, DCD, RI, GND
	RS-422, RS-485 4-wire	Tx+/Tx-, Rx+/Rx-, GND
	RS-485 2-wire	Data+/Data-, GND
Power requirement	DC 9V to 30V, 400 mA@12V	
Dimensions	169×93×29 mm ³ (W×D×H)	
	169×99×29 mm ³ with connectors	
Weight	500 g	

Table 4: Characteristics of NetCom 411 and 413

2.2.2.4. NetCom 811 and 813

Serial connector	DB9 female (similar to Modem)	
Serial ports	8 × RS-232 configured by DIP switch, (RS-422/485 on NetCom 813 only)	
Serial signals	RS-232	TxD, RxD, RTS, CTS, DTR, DSR, DCD, RI, GND
	RS-422, RS-485 4-wire	Tx+/Tx-, Rx+/Rx-, GND
	RS-485 2-wire	Data+/Data-, GND
Power requirement	DC 9V to 30V, 600 mA@12V	
Dimensions	169×93×42 mm ³ (W×D×H)	
	169×99×42 mm ³ with connectors	
Weight	900 g	

Table 5: Characteristics of NetCom 811 and 813

2.2.2.5. NetCom 811RM and 813RM (19" version)

Serial connector DB9 male (similar to PC)
Serial ports 8 × RS-232 configured by DIP switch,
(RS-422/485 on NetCom 813RM only)

Serial signals	RS-232	TxD, RxD, RTS, CTS, DTR, DSR, DCD, RI, GND
	RS-422, RS-485 4-wire	Tx+/Tx-, Rx+/Rx-, GND
	RS-485 2-wire	Data+/Data-, GND

Power requirement AC 100V to 240V, 47-63Hz, 25VA

Dimensions 258×149×45 mm³ (W×D×H)
278×155×46 mm³ with connectors

Weight 1350 g

Table 6: Characteristics of NetCom 811RM and 813RM

2.3. PACKING LIST

- √ VS NetCom
- √ Power supply adapter,
 - 9V 0.5A for NetCom 111, 113 and 211
 - 12V 1 A for NetCom 411 and 413
 - 12V 1 A for NetCom 811 and 813
 - Power cord for NetCom 811RM and 813RM
- √ Serial Null Modem adapter for each port
- √ CD-ROM with driver and configuration software
- √ Quick Installation Guide

3. HARDWARE CONFIGURATION

3.1. POWER SUPPLY

The NetCom device is powered by a single 9-30V power supply. It requires 200 mA up to 1400 mA of current, depending on the device type and voltage supplied. A suitable power supply adapter is part of the packaging. Connect the cable to the power jack at the rear side of NetCom, and put the adapter into the socket. For the 19" devices of course just plug the power cord into the socket.

The Power LED on NetCom (red) will light.

You can connect a power supply of your choice, providing the technical requirements are met.

3.2. ETHERNET

The connector for network is the usual RJ45. Simply connect it to your (switching) Hub. When the connect is done the Link LED on NetCom (yellow) will light. When data traffic occurs on the network, this LED will blink. It depends on your network whether a 100Mbit or a 10Mbit connect will be established. A 100Mbit net causes the Speed LED on NetCom (green) to light, otherwise it will remain dark.

Red LED	Yellow LED	Green LED	Status
Off	--	--	Device off, no power
On	Off	Off	No connection
On	On	Off	10Mbit connection established
On	Blink	Off	10Mbit data transfer (traffic)
On	On	On	100Mbit connection established
On	Blink	On	100Mbit data transfer (traffic)

Table 7: LED Function

3.3. SERIAL PORT SIMPLE SETTINGS

There is one set of 4 (2) Dip switches to configure the operation mode of the NetCom Device. On NetCom 413, 813 and 813RM there is a separate set for each serial port. Before connecting a serial device, the serial port configuration must be completed.

Warning: a bad configuration may cause serious damage in the NetCom or the connected device.

To avoid these problems, it is recommended not to connect a device to the serial ports in the first installation. Also all serial ports should be configured for RS232. This is done by setting the DIP switches like these examples. Depending on your NetCom Device you have two or four positions:

NetCom 211 Other devices

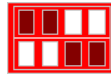

4. WINDOWS DRIVER QUICK INSTALLATION

This section describes the minimum steps required to install the Windows Driver and Management programs. Most configuration options are ignored. They are covered in later sections.

Before starting installation, it is essential to have an IP configuration ready for the NetCom Device to install. You may read the section TCP/IP Description below. In many networks the default configuration is fine. If in doubt, please ask your Network Administrator for help.

The following description is based on Windows XP Professional, with Service Pack 2 installed. The installation on other configurations of Windows XP is similar.

4.1. INSTALLATION PROCEDURE

The installation of drivers is described first. This is followed by a procedure to verify a correct installation. The last part of this section is the uninstall process.

4.1.1. START THE INSTALLATION WIZARD



vsnsetup.exe

Image 1:
Installation Wizard

This is the Installation Wizard, it is named VSNSETUP.EXE. You'll find it on the CD-ROM shipped with the NetCom, in the directory responsible for your operating system. The drivers are also available on the Internet, in the latest version. The Installation Wizard for Windows NT is named VSNSTUNT.EXE. Start this program to install the drivers.

Your screen displays a Vscom logo. Select the folder to install programs and drivers into. In most situations the suggested setting is fine, just hit enter.

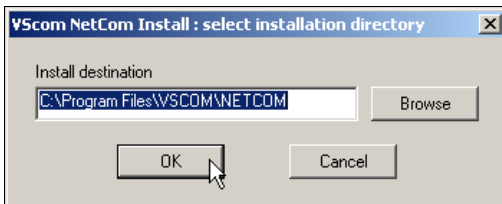

Image 2: Start Driver Installation

4.1.2. FIND AND CONFIGURE NETCOM DEVICES

Some files are copied to your hard disk, this is the usual process similar to other Windows installations. When all files are copied, the NetCom Manager¹ program is started. This searches for all NetCom Devices on your network.

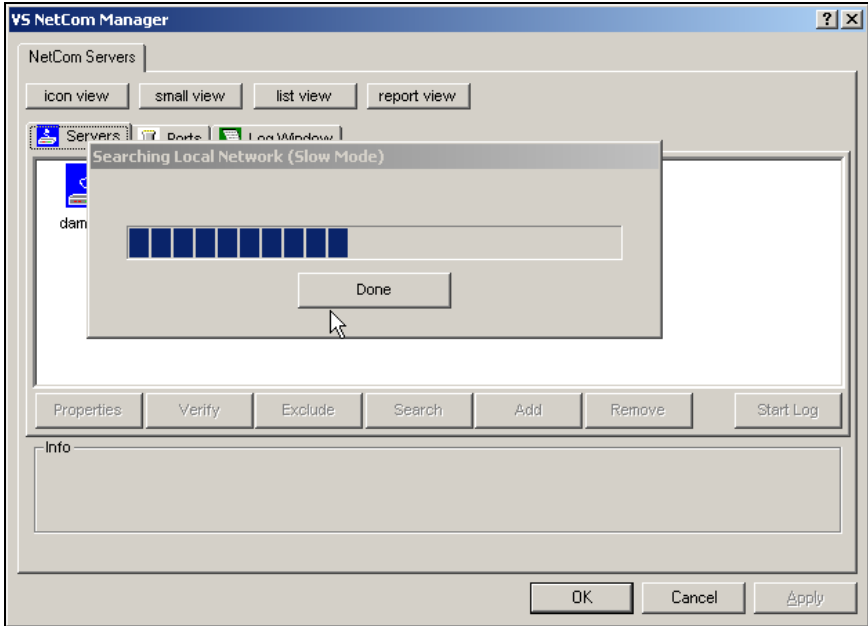
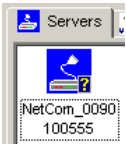

Image 3: Discover and Select NetCom Devices for Installation

After short time the search process is finished. All discovered NetCom are listed. In your very first installation of NetCom Devices and Drivers you should connect only one NetCom to your network. This single Device is listed here. Identify it by comparing the serial number shown in the NetCom Manager.



¹ This program is covered in detail in a later section. For now follow the minimum steps.

4.1.2.1. Configure IP Parameters

As mentioned above, it is important to configure the NetCom to operate in your network. In many networks this is done by a special server. Please ask your Network Administrator for information. If you need to define parameters manually, double-click the devices icon.

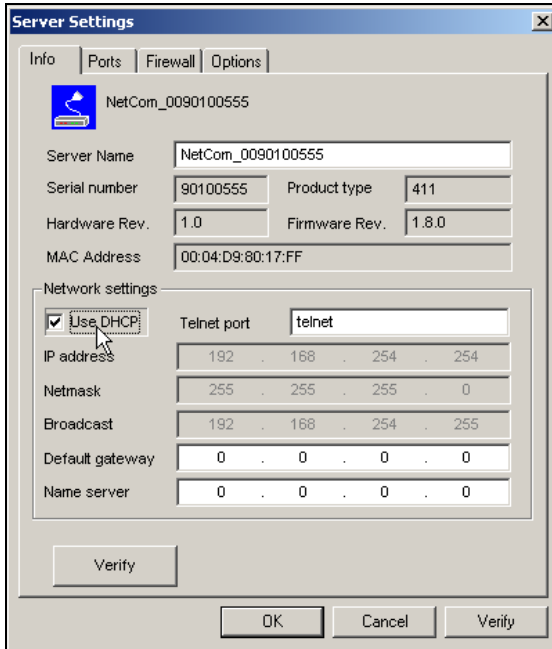

Image 4: Define NetComs IP Configuration

This panel opens. Deselect the Option of “Use DHCP”, and place your parameters as “IP address”, “Netmask” and “Broadcast”. Click on the “OK” button.

4.1.2.2. Configure Firewall

As you will see in Image 4 the driver may also operate by traversal of a Network Firewall. This requires a special configuration, which is skipped here. Please read in detail in section 5.2.6 Manual Detection/Installation of a NetCom. For now proceed with the standard installation.

4.1.3. INSTALL DRIVERS

You are now back in the NetCom Manager. Click the “OK” button, the installation continues. Windows detects the serial ports on the fresh NetCom as new Hardware. Since Windows XP Service Pack 2 you are asked about to get latest drivers.



Image 5: Use current drivers dialog

There are no later drivers on the Windows Update website. Select the third item, and click on “Next”. This question neither appears on Windows XP prior to SP2, nor on any previous Windows version.

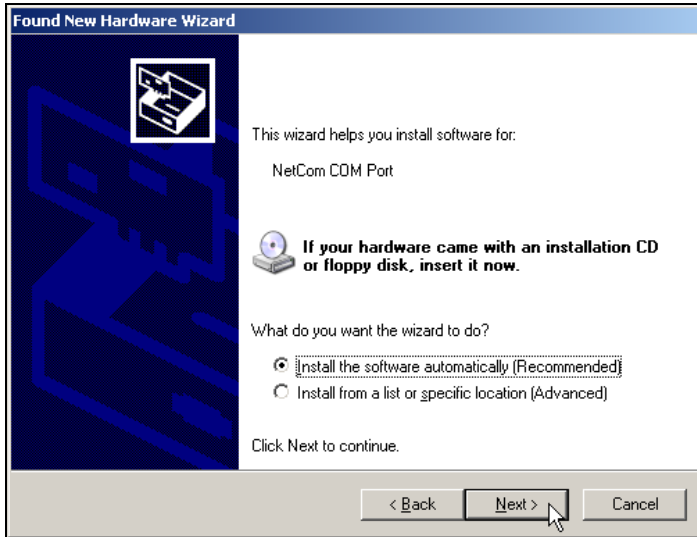

Image 6: Install drivers for the serial ports

The pre-selected automatic installation is fine, just click on “Next”. The driver files are already copied to your hard disk. Now Windows installs them in the system directory. To “Finish” the installation click on that button as it appears.

These latest steps happen for each serial port on the NetCom Device. Just repeat the procedure, until all ports are successfully installed. Windows will show you this.

In most situations it is not required to reboot the system. Of course you can do that now, to test the drivers.

4.2. VERIFY THE INSTALLATION



Image 7: VScom drivers in the Start Menu

In the Start Menu you’ll find “Vision Systems GmbH”, a new program group. The installed programs are the NetCom Manager and an option for uninstallation. This group is not installed on Windows NT.

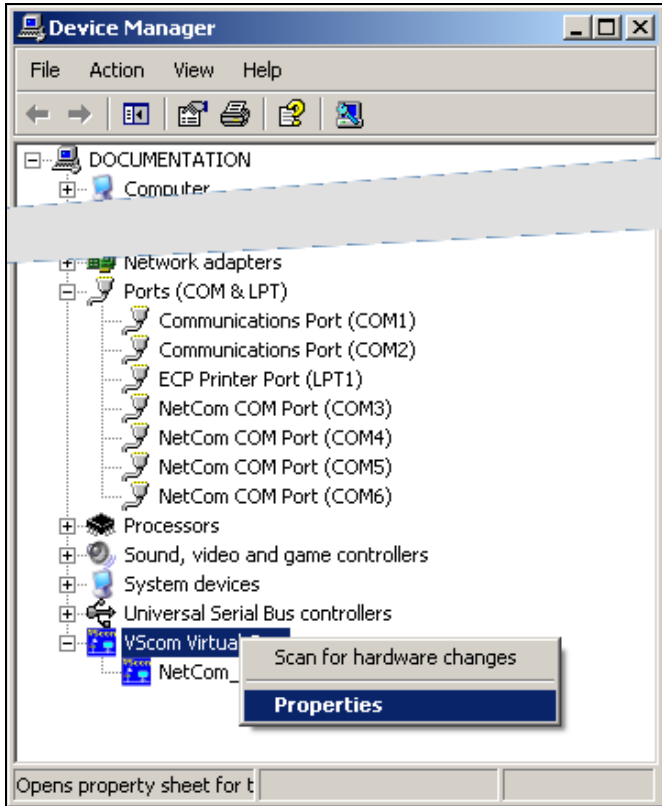

Image 8: NetCom in Device Manager

In the Device Manager the serial ports are listed in the usual section “Ports”. Additionally there is a new device class “Vscom Virtual Com”. All installed NetCom Devices are listed herein. The available options are described later.



Image 9:
NetCom Manager NT

On Windows NT there is no Device Manager. You’ll find the serial ports listed in the Control panel in the “Ports” applet. To configure the NetCom and special port options, there is a new applet named NetCom Manager.

4.3. UNINSTALL THE DRIVERS

To completely uninstall the NetCom Drivers and files, there are three methods. The usual way is to use the Add/Remove Programs applet in the Control Panel, and remove the NetCom Drivers. This will start the NetCom uninstallation program.



Image 10: Uninstall NetCom Drivers

As a second way you may start the Uninstall program in the start menu. The third method is to start the Installation Wizard again. This will detect the drivers on the system. You have the options to repair the current installation, or to remove the installed drivers.

5. SOFTWARE CONFIGURATION

The NetCom Devices may also be used without the installation of a driver software. Customer applications contact the NetCom directly, using network functions. These setups require independent configuration of the NetCom Device and the serial ports. There are several ways to do this configuration. The NetCom offers a Webbrowser interface, a Manager program to use in Windows, configuration via serial port, via Telnet and also via SNMP. This SNMP option is not covered in this manual, please see separate documentation. The serial port option is a fallback, if every other way of configuration fails. The options are here described in the order Web, Manager program, Telnet and serial port.



Image 11:
NetCom Manager

Configurations via Webbrowser and via Telnet require a functional TCP/IP connection to the NetCom Device. And you must also know the IP-Address of the NetCom, to contact it. The easiest way to retrieve this information is the NetCom Manager program. So here is a very minimal description of this program. You find this program on the CD-ROM shipped with the NetCom Device. In Windows 2000, XP and 2003 it is named NETCOMMGR.EXE, while in Windows NT the name is NETCOMMGRNT.EXE. Just double-click to start it direct from the CD-ROM. If you already installed the drivers, the program is also in the Start Menu.

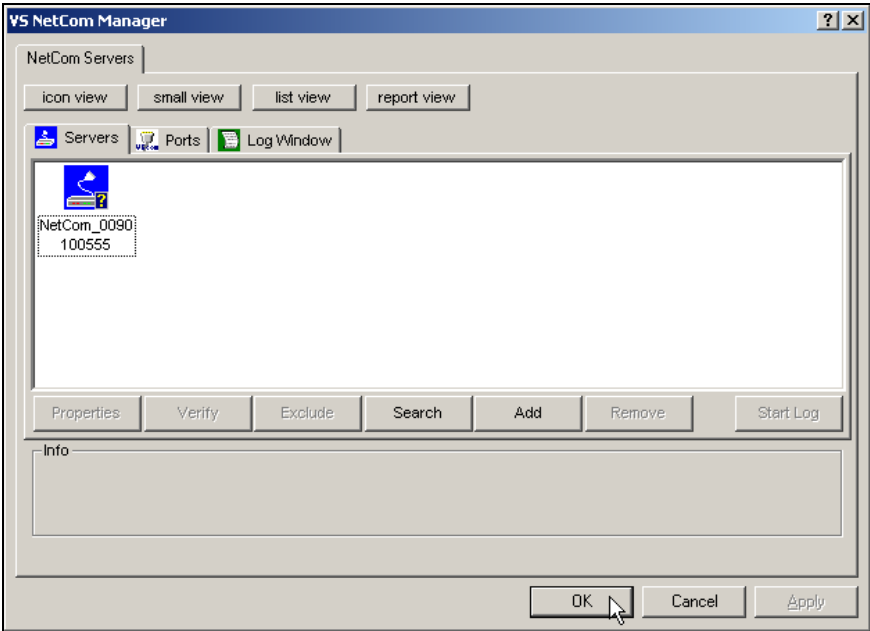

Image 12: NetCom Manager Servers Panel

Identify the NetCom Device by comparing the serial number. Double-click the Icon of the NetCom. You'll see the IP-Parameters. Note the "IP address", to use it in your browser or via Telnet.

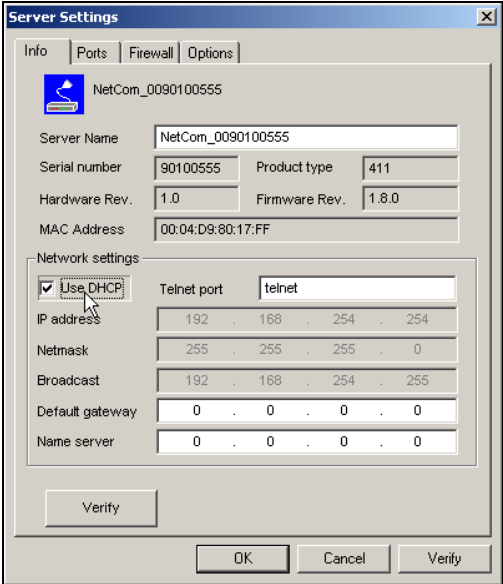

Image 13: NetCom IP-Parameters

5.1. CONFIGURE IN WEB-INTERFACE

Open your Webbrowser. In the address line type the address of the NetCom Server. In the example from above type <http://192.168.254.254> as the target. You may do this on any operating system you prefer.

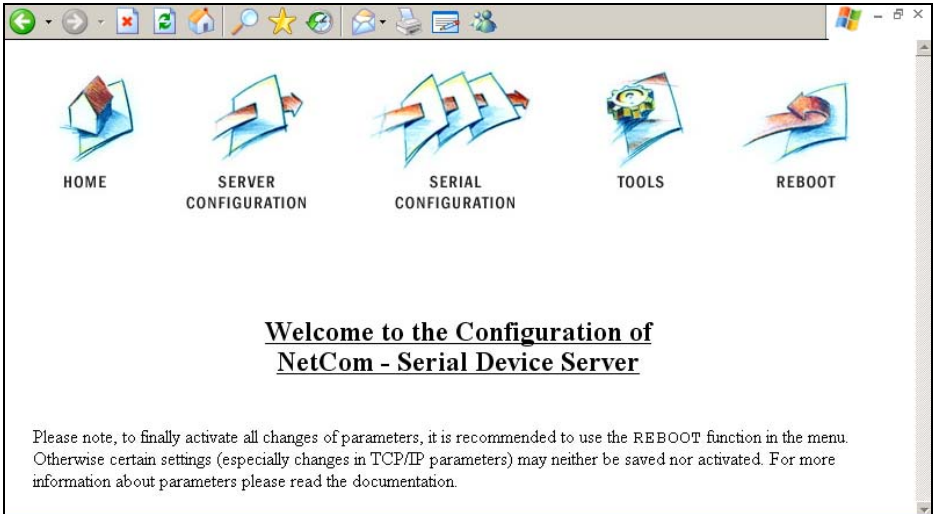

Image 14: Webinterface for configuration

The NetCom welcomes you with its “Home” screen. To access the different options of configuration, the images above function as a link. In many menus you’ll see a blue question mark. This is a symbol for help. When clicked a short explanation pops up, informing about the function of this parameter. Some other settings require a reboot to save and activate them. Whenever this situation occurs, the NetCom requests a REBOOT.

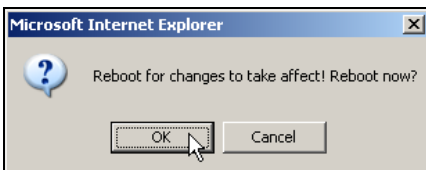

Image 15: Webinterface Request to Reboot

It is done like this here, you may reboot now, or do that later when the configuration is finished.

5.1.1.WEBBROWSER SERVER CONFIGURATION

The Server Configuration is a very long menu. It is divided in its logical sections throughout this document.

5.1.1.1. Server Info

Server Info	
Server Type	813
Software Version	2.0.0
Hardware Version	1.0
Serial Nr.	0060100892
UpTime	0 day(s) 06:43:11
Contact ?	<unset>
Location ?	<unset>

Image 16: Web Panel Server Information

Information about the selected NetCom is displayed as “Server Info”. Starting with the “Server Type”, this is the model of the NetCom, followed by the version of Software and Hardware. This will give a rough overview, which features are implemented, or need an upgrade of the firmware. The “Serial Nr.” is important to identify the device you are configuring right now. For further information the “UpTime” is listed. “Contact” and “Location” are User-defined information. They may later help to find the device in the installation, and the person responsible for management.

5.1.1.2. Server Parameter

Server Parameter	
Warning: for changes like network settings the server must be rebooted	
Server Name ?	NetCom_0010100494
MAC Address	00:04:D9:80:0F:F0
DHCP ?	Disabled
IP Address ?	192.168.1.247
Netmask ?	255.255.255.0
Broadcast ?	192.168.1.255
Gateway ?	192.168.1.1
DNS ?	192.168.1.3
Domain ?	NetCom.VScom.com.tw
ConfigPort ?	23
KeepAlive ?	Off
KeepAliveInterval ?	0

Image 17: Web Panel Server Parameter

The “Server Parameter” allow configuration of the NetComs name and of course all parameters in IP-settings. So far the name is just informative, e.g. in the NetCom Manager program or SNMP. Manual changes of IP parameters are only available with “DHCP” set as Disabled. When DHCP is not used, enter “IP Address” and “Netmask”, as well as the “Broadcast” address. “Gateway” is required, if there are Routers in the network. DNS is used to access other stations by name. The “ConfigPort” is

used to access the NetCom for administration via Telnet. It is suggested to use the standard value for Telnet, TCP port number 23. However it may be changed for different purposes. This does not change the function of the Telnet menus.

“KeepAlive” is an intrinsic function of the TCP/IP protocol. If used it causes network traffic, but problems are detected earlier. In a LAN this is usually not a problem. However, if used via DialUp connections this may cause problems. If this functions is used, you must define an interval in seconds. NetCom has a better chance to react on network

problems, or failed hosts. Even dropping an old connection may be useful in certain environments.

5.1.1.3. Authentication

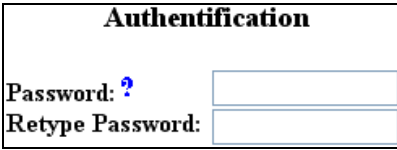

Authentication

Password:

Retype Password:

Image 18: Web Panel Authentication

”Authentication” sets a password to restrict access to the configuration of NetCom. To protect against accidental mistyping, you must type the Password again.

5.1.1.4. Date & Time

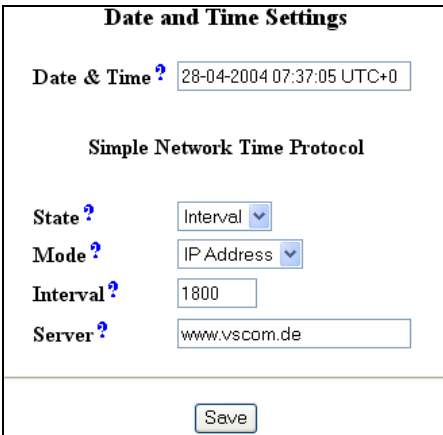

Date and Time Settings

Date & Time:

Simple Network Time Protocol

State:

Mode:

Interval:

Server:

Image 19: Web Panel Date & Time

It may be helpful to have a correct time setting in the NetCom. You may manually enter the time here. Please note, there is no real time clock with a battery backup in the NetCom. When the NetCom is restarted, the time is lost.

But since Firmware version 1.6 it is possible to configure NetCom for automatic time retrieval via SNTP. Define “State” for retrieval method of “Interval” or “Startup”, or “Off” of course. Parameter “Mode” is used to find the Time Server. It

may be defined direct, or by DHCP. The “Interval” in seconds instructs the NetCom to regularly check for an update of the internal time settings. The Time Server may be given by IP-Address, or by name. A name of course requires a DNS server, see at 5.1.1.2 Server Parameter above.

Below these options there is the button “Save”. This will store all configurations done here in the NetCom. In many cases NetCom requires a reboot to proceed.

5.1.2.WEBBROWSER SERIAL PORT CONFIGURATION

This is also a huge menu. Each serial port of the NetCom is listed in a separate Column. The top half of the parameters titled “Serial Settings” is directly related to common serial configurations. The bottom half titled “Transfer Settings” configures the operation mode of NetCom on the network. Each serial port is configured separately, there is no setting shared between ports.

5.1.2.1. Serial Settings

PortType	rs232
DefaultModel	16550
MaxBaudrate	460800
Model	16550
Baudrate ?	Manual
Manual ?	110
FlowType ?	XON/XOFF
DataBit ?	8
Parity ?	None
StopBit ?	1
RxFifoLength	2048
RxTriggerLevel ?	1248
TxFifoLength	2048
TxTriggerLevel ?	800

Image 20: Web Panel Serial Settings

When the NetCom is used via the Virtual Com Driver mode, the serial parameters are controlled by the application, which opened the serial port. However certain installations use a different operation, without Driver mode. Then the serial parameters must be defined separately. This is done in this panel.

Some NetCom devices allow to operate in RS422/485 modes. This is normally configured by DIP switches, the current setting is displayed as “PortType”. The serial port is based on standard UARTs, the type and maximum speed are also displayed. These are hardware parameters, and can not be changed.

The current UART “Model” may be changed to a less advanced type. In some situations it may be desirable to deactivate the FIFO memory, or some other options.

The “Baudrate” may be selected in a drop-down list, or entered manually. If Manual is selected in the list, the value in the respective field is used to transmit data. NetCom checks if the configuration is possible, and warns otherwise. “DataBit” per character, “Parity” and “StopBit” are quite usual parameters.

The FlowType is available as standard configuration. There is also an Advanced setting, which gives very specific control to the user.

Advance ▼		
	On	Off
AutoCTS	<input checked="" type="radio"/>	<input type="radio"/>
AutoRTS	<input type="radio"/>	<input checked="" type="radio"/>
AutoDSR	<input type="radio"/>	<input checked="" type="radio"/>
AutoDTR	<input type="radio"/>	<input checked="" type="radio"/>
AutoTxXOnXOff	<input checked="" type="radio"/>	<input type="radio"/>
AutoRxXOnXOff	<input type="radio"/>	<input checked="" type="radio"/>

Image 21: Web Panel Advanced Flow Control

NetCom can generate Events on RTS, DTR or as XON/XOFF, when the serial receive buffer is filled/emptied. It will also respect the state of CTS, DSR or XON/XOFF when sending data to the connected serial device.

The “RxTriggerLevel” defines when NetCom sends the received data to the host. If the amount of data is this high, the data is sent. It does not matter if there is still data coming on the serial line. If less data is received, the NetCom waits some time for further data, before sending the buffer.

The “TxTriggerLevel” operates similar for the transmission. If the defined amount is received from the network, the NetCom does not accept more data to transmit.

5.1.2.2. Transfer Settings

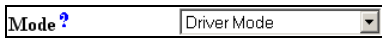

Image 22: Serial Port Mode Selection

The Transfer Settings allow different modes. They are selected by the basic “Mode” setting. Depending on the

current mode, only some of the many parameters are useful. The web configuration hides those parameters without function.

Basically the NetCom Devices can act as a server or as a client. As the main difference a server waits for clients to contact it, while a client actively contacts a server. A NetCom can do both, and partially both at the same time. Keep this in mind throughout this section.

5.1.2.2.1. Driver Mode

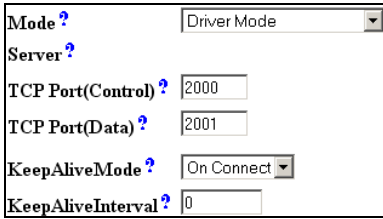

The screenshot shows a configuration window for 'Driver Mode'. It contains the following fields: 'Mode' is a dropdown menu set to 'Driver Mode'; 'Server' is a text field; 'TCP Port(Control)' is a text field with '2000'; 'TCP Port(Data)' is a text field with '2001'; 'KeepAliveMode' is a dropdown menu set to 'On Connect'; and 'KeepAliveInterval' is a text field with '0'.

Image 23: Web Panel Driver Mode

Only very few parameters have a function in “Driver Mode”. NetCom is operating as a *Server*. It accepts two connections per serial port. One connection is used to transmit the serial data, this is the “TCP Port(Data)”. And the other is used to transmit control information, “TCP Port(Control)”. This control connection includes the configuration of the serial port, as well as signals for changed Modem Status lines. This mode is required when the serial port is operated via the Virtual Com Driver, it is default.

The NetCom can check if the connected *Client* is still alive. This may be done, when a second Client wants to establish a connection (On Connect). It may also be done in regular intervals (Polling).

5.1.2.2.2. TCP Raw Server

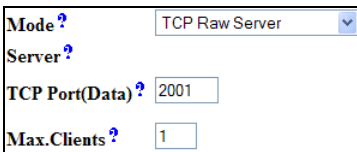

The screenshot shows a configuration window for 'TCP Raw Server'. It contains the following fields: 'Mode' is a dropdown menu set to 'TCP Raw Server'; 'Server' is a text field; 'TCP Port(Data)' is a text field with '2001'; and 'Max.Clients' is a text field with '1'.

Image 24: Web Panel TCP Raw Server

As TCP Raw Server NetCom operates very simple. It only waits for incoming data connections in Raw IP mode. As with the Driver Mode only the data connection is defined. As a special configuration NetCom allows for more than one connection at a time. If the number is raised, it is the responsibility of the customer to ensure correct operation.

5.1.2.2.3. TCP Raw Client

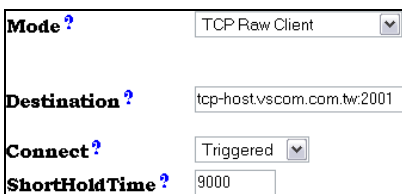

The screenshot shows a configuration window for 'TCP Raw Client'. It contains the following fields: 'Mode' is a dropdown menu set to 'TCP Raw Client'; 'Destination' is a text field with 'tcp-host.vsc.com.tw:2001'; 'Connect' is a dropdown menu set to 'Triggered'; and 'ShortHoldTime' is a text field with '9000'.

Image 25: Web Panel Raw Client

Also as Raw Client the NetCom requires very few parameters. Under certain conditions it establishes a Raw TCP connection to a pre-defined “Destination”. Since version 2.0 of the NetCom Firmware the Destination can hold multiple hosts as targets for a connection. They are entered as a comma separated list of DNS names or IP-Addresses. Each destination will have a TCP port number, separated by a colon. Instead of a single IP-Address or DNS name, a range of IP-Addresses is also valid. This range must be followed by the TCP port number, as in 192.168.254.12-192.168.254.17:2077.

The parameter “Connect” defines if NetCom uses the connections as Permanent, Triggered or DSR. With Permanent or Triggered any activity on the serial ports establishes the connection, inactivity of longer than the “ShortHoldTime” cause NetCom to close the connection. DSR is new since Firmware version 2.0, the TCP-connections follow the state of the DSR signal at the NetCom serial port. When it becomes active they are established, until DSR becomes inactive. At that moment the connections are dropped.

5.1.2.2.4. Null Modem Tunnel

Mode ?	Null Modem Tunnel
Server	
TCP Port(Control) ?	2000
TCP Port(Data) ?	2001
Client	
Destination ?	other.netcom.vicom.com.tw
TCP Port(Control) ?	2000
TCP Port(Data) ?	2001
Connect ?	Triggered
ShortHoldTime ?	9000
KeepAliveMode ?	On Connect
KeepAliveInterval ?	0

Image 26: Web Panel Null Modem Tunnel

This is a mixed mode, requiring parameters for server function and for the destination. The NetCom operates as a server while accepting connections in Driver Mode. If there is no current connection, the NetCom may establish a connection as a client. This is also a special connection, using the Driver Mode protocol. NetCom can will not only transmit serial data in both directions, it will also pass information about the current

settings of the Modem Status lines. And it will itself set the Modem Control lines as required by the other host. Since this operation requires another NetCom to accept the connection, both NetCom together operate as a long Null-Modem cable. The data is sent via a tunnel through the network.

The configuration as *Server* (top) requires the same parameters as the Driver Mode, hence “TCP Port(Control)” and “TCP Port(Data)”.

The configuration as *Client* (bottom) first require a destination. Here it is given by name, but a direct IP-Address may be more usual. On the destination there is also a “TCP Port(Control)” and “TCP Port(Data)” to accept the connect of the NetCom.

The connection is normally established in Triggered mode, i.e. when some event occurs on the serial port. It is hold for the defined “ShortHoldTime”. It is also possible to have the connection Permanent. As in the normal Driver Mode the function of a connected client can be checked via KeepAlive signals in different modes.

5.1.2.2.5. IP-Modem

Mode ?	<input type="text" value="IP Modem"/>
TCP Port(Data) ?	<input type="text" value="2001"/>
Destination ?	<input type="text"/>
IP Modem Config ?	<input type="text"/>

Image 27: Web Panel IP-Modem

The serial port of a NetCom may mimic (emulate) a serial modem. This feature is available since Firmware version 2.0 of the NetCom. There is the separate section **Fehler! Verweisquelle**

konnte nicht gefunden werden. defining this functionality. Here are the basic network parameters only. A modem accepts connections from the network, in this case via TCP/IP. The TCP port for this is defined as the “TCP Port(Data)”. This is the only parameter required to set here. All other values are normally defined via AT-commands. However for short, “Destination” allows for up to four predefined targets, available with special Dial commands. The “IP Modem Config” is known as the Init String in standard modems.

5.1.2.2.6. TCP Advanced Settings

Mode ?	<input type="text" value="TCP Advanced Settings"/>
Server ?	<input type="text" value="Off"/>
TCP Port(Control) ?	<input type="text" value="2000"/>
TCP Port(Data) ?	<input type="text" value="2001"/>
Max.Clients ?	<input type="text" value="1"/>
Client ?	<input type="text" value="On"/>
Destination ?	<input type="text" value="adv-host.vscorn.de"/>
TCP Port(Control) ?	<input type="text" value="0"/>
TCP Port(Data) ?	<input type="text" value="2001"/>
Connect ?	<input type="text" value="Triggered"/>
ShortHoldTime ?	<input type="text" value="0"/>
KeepAliveMode ?	<input type="text" value="On Connect"/>
KeepAliveInterval ?	<input type="text" value="0"/>

Image 28: Web Panel TCP Advanced Settings

All of the above operation modes are special configurations for options. In some situations none of the pre-defined modes fit the customers needs. When this is the case, the TCP Advanced Settings offer the configuration of any Transfer parameter. Unusual combinations of Modes are possible with this, also standard modes with unusual parameters.

5.1.2.2.7. UDP Data Transfer

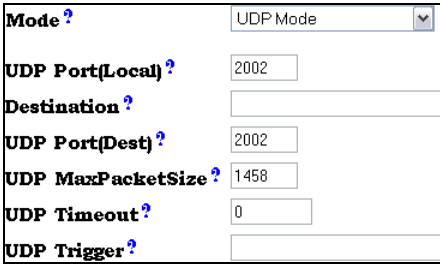

Image 29: Web Panel UDP Data Transfer

configured by IP-Address or name, plus the target “UDP Port(Dest)”.

“UDP MaxPacketSize” is a limit for the size of UDP packets. When the amount of data received on the serial port reaches this limit, the UDP Frame is assembled and sent to the destination.

“UDP Timeout” defines when NetCom sends the received data as a UDP Frame. If the reception of serial data is interrupted for this time (in milliseconds), the data sampled so far is sent to the destination.

“UDP Trigger” defines a sequence of characters. As soon as this sequence is detected in the received data, all data up to the end of this Trigger is sent to the destination. In most situations such a Trigger includes control or other special characters. Enter them numeric: as \xHH where HH is the hexadecimal code of the character, or as \OOO where OOO is the octal code of the character. The backslash itself must be doubled as \\.

5.1.2.2.8. Print Server Function

Firmware Version 2.2 introduces the function as a Print Server according to RFC1179, also called a »Line printer daemon«. A print server is accessed through its IP Address via one specified TCP Port (see Server Parameter). Data is handled in distinct queues, each with a certain name. Each queue is handled by a certain serial port, and the data is sent to the serial printer attached to this port.

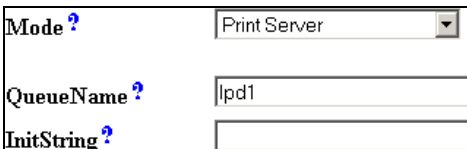

Image 30: Web Panel Print Server Configuration

The UDP mode is available as a function since the version 1.4 of the firmware. UDP sends data in single packets instead of a stream. This protocol requires a “UDP Port(local)” for listening to incoming data. Other stations on the network send their data to this port. The “Destination” host is

configured by IP-Address or name, plus the target “UDP Port(Dest)”.

“UDP MaxPacketSize” is a limit for the size of UDP packets. When the amount of data received on the serial port reaches this limit, the UDP Frame is assembled and sent to the destination.

“UDP Timeout” defines when NetCom sends the received data as a UDP Frame. If the reception of serial data is interrupted for this time (in milliseconds), the data sampled so far is sent to the destination.

“UDP Trigger” defines a sequence of characters. As soon as this sequence is detected in the received data, all data up to the end of this Trigger is sent to the destination. In most situations such a Trigger includes control or other special characters. Enter them numeric: as \xHH where HH is the hexadecimal code of the character, or as \OOO where OOO is the octal code of the character. The backslash itself must be doubled as \\.

5.1.2.2.8. Print Server Function

Firmware Version 2.2 introduces the function as a Print Server according to RFC1179, also called a »Line printer daemon«. A print server is accessed through its IP Address via one specified TCP Port (see Server Parameter). Data is handled in distinct queues, each with a certain name. Each queue is handled by a certain serial port, and the data is sent to the serial printer attached to this port.

Each serial port configured for Print Server operation has its separate “QueueName”. The default value is »lpd« plus port number. The “InitString” is a special feature of NetCom. This

string is sent to the serial printer at the beginning of the next queued print job. The definition is in section 8.2.2.1 below.

5.1.3.WEBBROWSER NETCOM TOOLS

Since Firmware version 1.6.0 the available tools are:

- The Ping utility to check if a station is available.
- Statistic information for each serial port.
- The Netstat utility to monitor used TCP connections.
- The option to update the firmware.
- Saving of Configuration to / Loading from a file.
- Syslog
- DebugLog

5.1.3.1. Ping

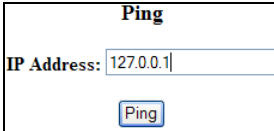

Image 31: Web Panel Ping

Enter the IP-Address or the name of a station in the field, and click the “Ping” button. The network connection is checked by sending certain ICMP data packages.

```
PING 127.0.0.1 from 192.168.1.87 : 44 (72) bytes of data
52 bytes from 127.0.0.1: icmp_seq=0 ttl=255 time=1.560 msec
52 bytes from 127.0.0.1: icmp_seq=0 ttl=255 time=1.542 msec
52 bytes from 127.0.0.1: icmp_seq=0 ttl=255 time=1.542 msec
back
```

If the target responds, the network between the NetCom and the target is operational. The time required for an echo depends on the speed of the network. In a typical Ethernet this is only very few Milliseconds, while it can be several seconds throughout the Internet.

5.1.3.2. Statistics



Image 32: Web Panel Statistics Port Selection

Select the serial port to see its statistical information.

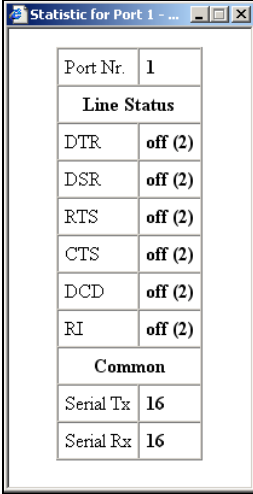

Image 33: Web Panel Port Statistics

The statistics window reports the state of the modem status and control signals. Also the number of state changes. The number of characters sent and received is shown at the bottom.

5.1.3.3. Netstat

Netstat

[View connections](#)

Use Netstat to see the actual connection status of NetCom. This is a standard tool for network debugging.

Image 34: Web Panel
Start Netstat

Update			
Proto	Local Address	Foreign Address	State
tcp	0.0.0.0:23	0.0.0.0:0	LISTEN
tcp	0.0.0.0:80	0.0.0.0:0	LISTEN
tcp	0.0.0.0:2000	0.0.0.0:0	LISTEN
tcp	0.0.0.0:2001	0.0.0.0:0	LISTEN
tcp	0.0.0.0:2010	0.0.0.0:0	LISTEN
tcp	0.0.0.0:2011	0.0.0.0:0	LISTEN
tcp	0.0.0.0:2020	0.0.0.0:0	LISTEN
tcp	0.0.0.0:2021	0.0.0.0:0	LISTEN
tcp	0.0.0.0:2030	0.0.0.0:0	LISTEN
tcp	0.0.0.0:2031	0.0.0.0:0	LISTEN
tcp	192.168.1.243:80	192.168.1.42:1280	TIMEWAIT
tcp	192.168.1.243:80	192.168.1.42:1281	ESTABLISHED
udp	0.0.0.0:161		
udp	0.0.0.0:19970		
udp	192.168.1.243:32331		

Image 35: Web Panel Netstat Output

A “Foreign Address” of 0.0.0.0 is listed when NetCom is waiting for an incoming connection (LISTEN). If the value is not 0.0.0.0, the connection is either active (ESTABLISHED) or closed (TIMEWAIT).

5.1.3.4. Firmware

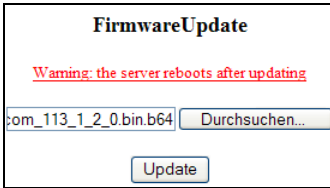

FirmwareUpdate

Warning: the server reboots after updating

com_113_1_2_0.bin.b64

Image 36:
Web Panel Firmware Upload

To upload a new version of the firmware, put the name of the file in the field. Your webbrowser may allow to search for the file. Click on the “Update” button. While loading the file is checked. If it is valid, it is stored in the Flash Memory. When the upload is finished, NetCom will Reboot.

5.1.3.5. Save and Load Configuration

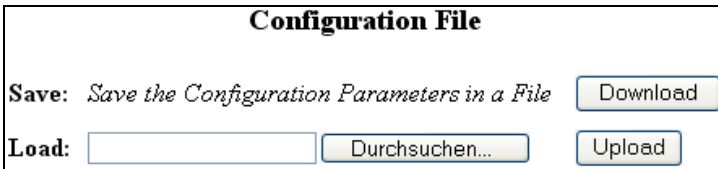

Configuration File

Save: *Save the Configuration Parameters in a File*

Load:

Image 37: Web Panel Save/Load Configuration

It is possible to save the actual configuration to a text file. This is first implemented in Firmware version 1.6. Of course it is also possible to load the saved configuration into a NetCom.

5.1.3.6. Logging and Debug

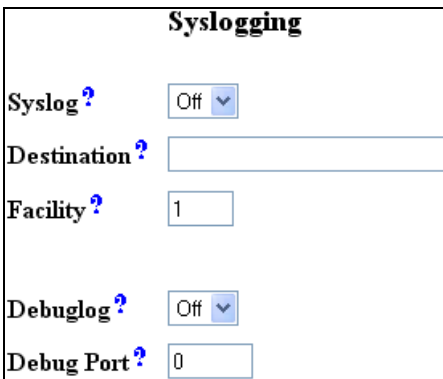

Syslogging

Syslog? ▾

Destination?

Facility?

Debuglog? ▾

Debug Port?

Image 38: Web Panel Syslog & Debug

Syslogging requires a server the information is sent to. Facility allows to select the data sent to that server.

For Debuglog the NetCom behaves as the server. Open a TCP connection to the configured port, and receive all information generated.

5.2. CONFIGURE WITH MANAGER PROGRAM

Shipped with the NetCom Devices there is a versatile program for Windows Operating System, named NetCom Manager. This program shall detect, manage and configure the NetCom Devices in your network. You can start it by several ways. First of all it is stored on the CD-ROM, named NETCOMMGR.EXE (NETCOMMGRNT.EXE on Windows NT). It is possible to start it directly from the CD-ROM.



See this Icon to the left. When the Virtual Com Drivers are installed, there are more options to run the program. In Windows NT the same Icon appears in the Control Panel, to start the NetCom Manager program.

Image 39:
NetCom
Manager

In Windows 2000, XP and 2003 Server the driver software installs a new device class “Vscm Virtual Com”. The properties of the class open the NetCom Manager. Additionally the installation of the drivers created a new program group in the Start Menu.

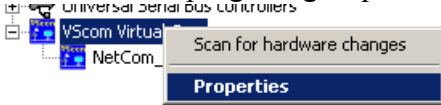

Image 41: NetCom Manager in Device Manager



Image 40: NetCom Manager in Start Menu

This section of documentation focuses on management of the NetCom Devices. The options to configure driver-specific options of the serial ports are skipped here. This includes some buttons and panels. They are described in total below, in the documentation of the drivers and panels.

While in the configuration process, a click on a button or a double-click on an item opens properties or other options. In many situations, a right-click with the mouse opens context-sensitive options. Just try it out. The NetCom Manager is designed to help configure driver options. So for very detailed configuration of a NetCom, it is better to use the Webbrowser interface, or do it via Telnet. However, here are the options.

5.2.1. STARTING NETCOM MANAGER

When NetCom Manager is started, it will “Search” the NetCom in your LAN by SNMP. This process may take up to 30 seconds. The devices in a LAN are typically found in the first seconds. If this is enough for you, you can stop the search by click on the “Done” button.

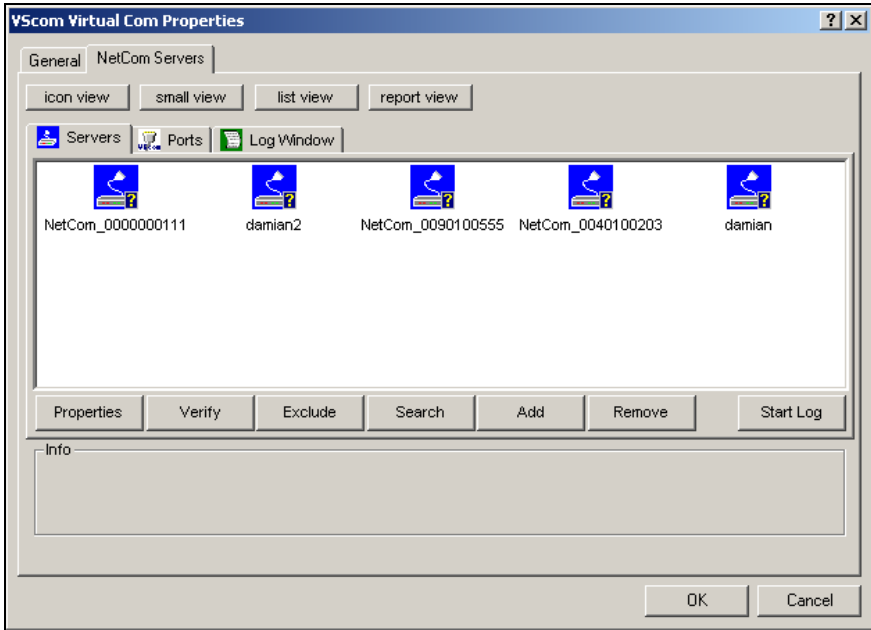

Image 42: NetCom Manager “Servers” Panel

The NetCom are listed here in the “Servers” panel. Since the “Search” uses broadcast mechanisms, the range is limited. If you have routers in your network, or you contact some NetCom via Internet, you must “Add” them manually. Enter the network parameters to access the NetCom.

Select a NetCom, and click on the “Properties” button, double-click the Icon, or use a right click. Using “Verify” the NetCom Manager contacts the NetCom to check if it is properly configured and online. “Exclude” is only useful in conjunction with the Virtual Com Drivers, so skipped here. “Search” repeats the search from the program start, and may be used at any time. “Remove” removes a server from this list. This option is most often used to clear old data from the drivers database. For monitoring purposes you may select a NetCom, and “Start Log” for

this. It may be done for several Devices at the same time. The output is visible in the “Log Windows” panel.

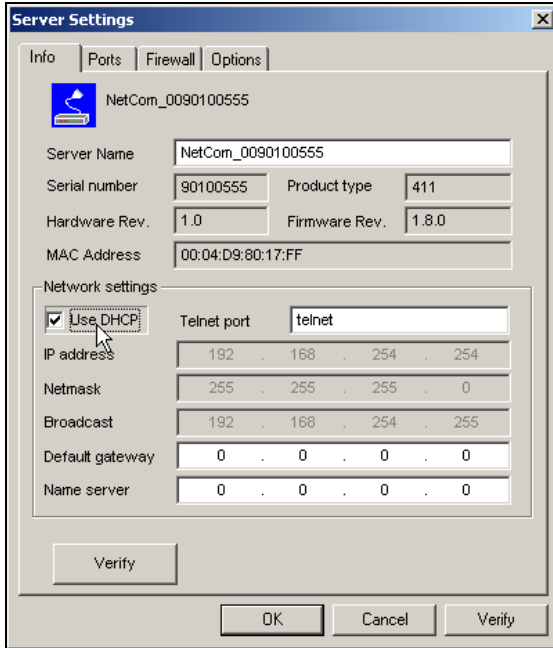

Image 43: NetCom Server Settings

5.2.2.NETCOM SERVER SETTINGS - INFO

As described above, open the “Properties” of a NetCom Device. The Server Settings start with the “Info” panel. Configure the options as your network requires.

The “Server Name” is just for information. As factory setting it includes the serial number of the device. You may change it to any string, since there is no functionality related to the name. This name is listed in the Server panel of NetCom Manager. The next parameters are fixed, and displayed for information only.

The “Telnet port” allows to configure this NetCom via Telnet. The value is a TCP port. Factory setting is the standard port for Telnet, 23.

By default the NetCom is set to “Use DHCP” for automatic configuration of IP parameters. This is the suggested method. However there are several situations where this option can not be used. In this case deactivate it. When inactive, other parameters may be changed.

The basic parameters “IP address” and “Netmask” are mandatory. If any of these is changed, the NetCom Manager calculates a matching address for “Broadcast”. You may also change this address.

The DHCP option will also configure the “Default gateway” and the “Name server”. Without DHCP you must enter these parameters by yourself. However they are not required in all configurations. So enter 0.0.0.0 if they are not used.

5.2.3.NETCOM SERVER SETTINGS - PORTS

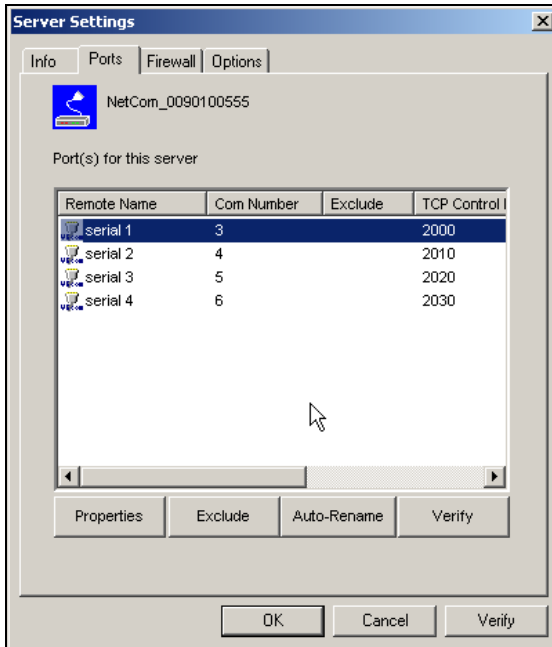

Image 44: NetCom Ports Panel

The “Ports” panel lists all serial ports of a NetCom. Some of the options are driver related, e.g. the “Com Number”. Each serial port may operate via three TCP ports. The “TCP Control Port” is used in the Virtual Com Driver mode, and also in Null-Modem Tunnel. If Driver mode is not desired, this parameter is ignored almost always.

The “TCP Data Port” is used to transmit data to and from the serial port. Use the default, or change the value to the settings required for your network. There is also a “UDP Data Port”, used in packet data transfer. You can not switch the NetCom to UDP mode with the Manager. But if it is already in this mode, you can change this basic parameter.

5.2.4.NETCOM SERVER SETTINGS - FIREWALL

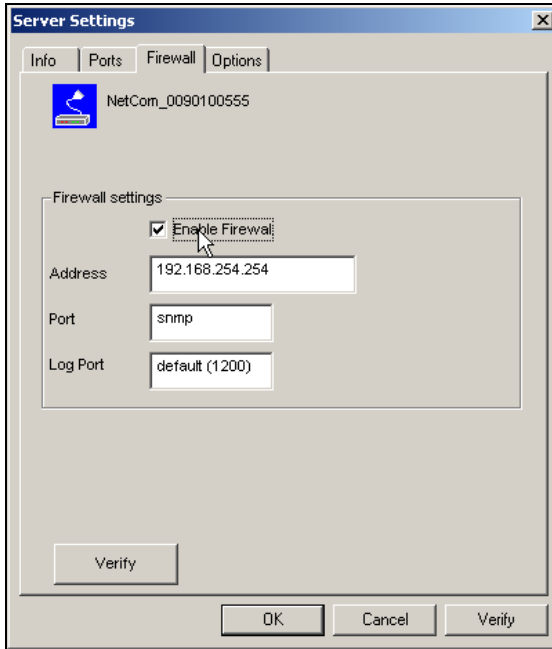

Image 45: NetCom Firewall Panel

Many networks use a Firewall to protect the stations in the network from other networks, including the Internet. In some situations the contact to a NetCom must pass through such a Firewall. To do this you must “Enable Firewall”, and enter the “Address” of the Firewall.

The Manager configures a NetCom via SNMP, which uses UDP. The Firewall must have a special “Port” to receive those data, and to transfer it to the internal network. Enter this port here.

The same scheme applies to the logging option. By default a NetCom listens on port 1200 for logging connections. The Firewall must also have a special “Log Port” to receive this connection, and to transfer it to the NetCom.

The NetCom does not need any configuration to operate in a Firewall protected environment. This configuration here is for installation of the drivers. There is a Firewall tutorial section later in this manual.

5.2.5.NETCOM SERVER SETTINGS – OPTIONS

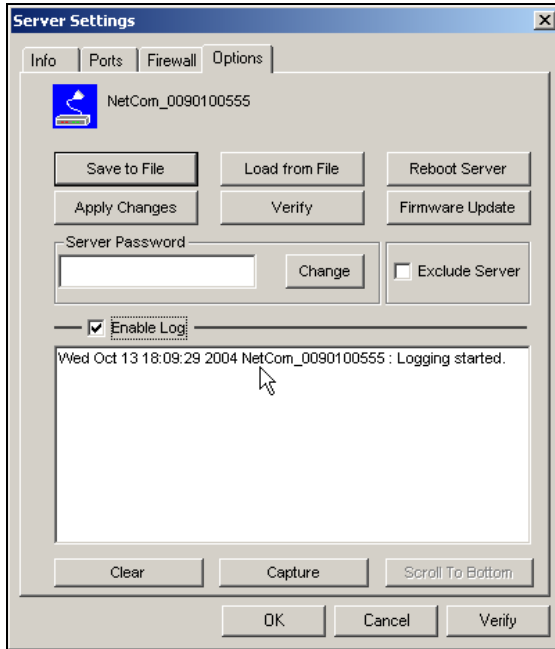

Image 46: NetCom Options Panel

This Panel is available since software version 1.4.8.0, in this enhanced version. A “Save to File” of the configuration is available, as well as the opposing “Load from File” of this data.

You can also “Reboot” the NetCom. This may be useful, e.g. if an old connection blocks access to the NetCom.

The button “Apply Changes” commits all parameter settings done so far to the NetCom. And the “Verify” checks the current settings by reloading the status from the NetCom to the Manager program.

When you want to install a “Firmware Update”, use this button.

The NetCom may be protected for access, in this case you must place the current “Server Password” in the dialog. The option to change the password is reserved for a future extension. “Exclude Server” is related to the Driver installation only.

You may “Enable Log” to see events at the NetCom, for monitoring. If enabled, the log will also appear in the central “Log Window”. At any time it’s possible to “Clear” the log, or “Capture” the data to a file.

5.2.6. MANUAL DETECTION/INSTALLATION OF A NETCOM

Sometimes the NetCom Device Server can not be detected by the automatic in the NetCom Manager. To detect and configure devices the protocol SNMP is used. The detection is done by sending out a broadcast on all available network interfaces of your computer. This SNMP broadcast is realized as an Ethernet broadcast. Such a broadcast is only transmitted through Hubs and Switches. When there is a router between the computer and the NetCom, the broadcast is not transmitted. This is especially the case when the NetCom is located somewhere via Internet, but also in big networks of some companies. If this is the case, the detection has to be done manually. Refer to Image 42 and “Add” the NetCom by use of the button. Enter the IP-Address of the NetCom in the NetCom Server Settings, and click the button “Verify”. Since now the IP-Address of the NetCom is known, the NetCom Manager sends a request directly to this target. This directed SNMP request is transported, even by routers. The NetCom sends the normal reply, giving all required information to the NetCom Manager. Now it is possible to configure all options as usual. Also the drivers for virtual serial ports are installable now.

5.2.7. FIREWALL TRAVERSAL CONFIGURATION

There are more difficult situations with a Firewall between the NetCom and the NetCom Manager. Many Firewalls protect the internal LAN by using the Feature of NAT (Network Address Translation). In this situation the IP-Address of the internal device is not visible on the Internet. Only the Firewall can be contacted via its public IP-Address. The NetCom Manager and the driver software for the virtual serial ports can handle such setups. But this requires certain configurations.

5.2.7.1. SOHO Firewall example

The most easy situation for such a setup is by using a very simple SOHO router as the Firewall. This configuration will show the principle of the technical details. Those principles can be transferred very easy to the configuration of more complicated installations. On the SOHO router there is only one public IP-Address on the external side, and typically 254 internal IP-Addresses for the LAN side. These internal addresses may be assigned by DHCP or static. Such routers offer a feature typically named “DMZ”, which in fact is only a single exposed host. It is recommended not to use the “DMZ” for several reasons, some of them are security related.

5.2.7.2. SOHO Virtual Servers

The router also offers “Virtual Servers”, which is the option required for NetCom installation. These “Virtual Servers” (here named VSrv for short) operate by a technique called PAT (Port Address Translation). Certain data addressed to the public IP-Address of the router are forwarded to the internal private address of the NetCom. The NetCom can be contacted via the public IP-Address of the router.

First you need to configure the router for some VSrvs. As the absolute minimum there is one VSrv for the NetCom device itself, and another two VSrvs for each serial port of the NetCom. Those VSrv are to be configured for TCP or UDP transmissions. Please read in the manual of your router how to do that. You need a port for the external interface, and an IP-Address plus a port for the LAN side. The IP-Address is of course that of the NetCom. As an example the most easy device is a NetCom 113. The internal port for SNMP is 161 for UDP. The serial port requires ports 2000 and 2001 for TCP.

Function	External port	Internal port
SNMP	8161/UDP	161/UDP
Control	9000/TCP	2000/TCP
Data	9001/TCP	2001/TCP

Configure your router for these example VSrvs, and use the internal IP-Address of the NetCom for the targets. Connect the NetCom to your LAN. Now you are ready for a very first test. Use Telnet to connect to the Data port of the NetCom serial port. Open a console (DOS Box) and type the command

```
Telnet <routers-IP-Address> 9001
```

You will be connected to the serial port. Every character you type is sent out of the serial port, and every received data is shown on your screen. The serial parameters are preconfigured in your NetCom.

5.2.7.3. NetCom Detection through SOHO Firewall

Now open the NetCom Manager as in section 5.2.6 above, and click the “Add” button. You again get the NetCom Server Settings dialog. But now you have to select the panel named “Firewall”.

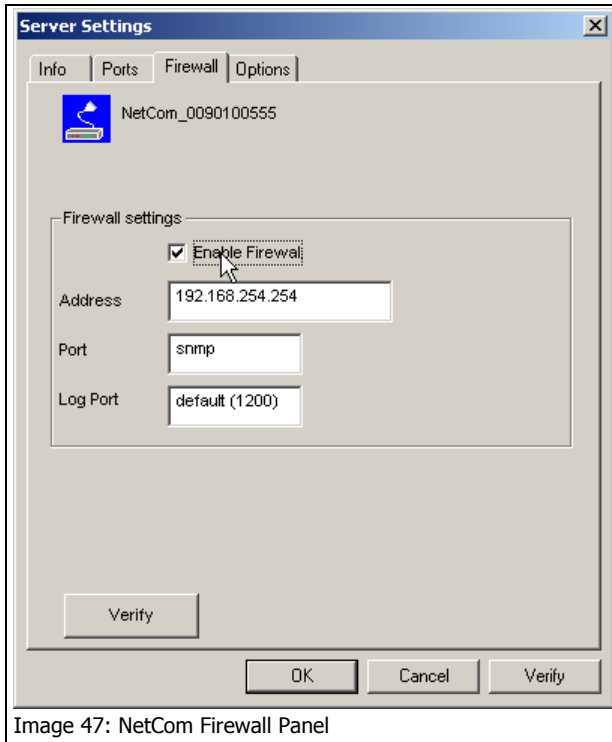

Image 47: NetCom Firewall Panel

Check the Option “Enable Firewall”, and enter the IP-Address of the router in the “Address” field. In the field “Port” enter the target port for the SNMP configuration. From the Virtual Server example above this is port 8161. Since there is no configured VSrv for Logging, ignore this field. Click the button “Verify” to have the NetCom Manager contact the router. This is a directed request, so there is no problem with broadcasts. Some ISP will block the SNMP protocol, which typically means they do not transport data for 161/udp to their customers (this is the first reason why port 8161 was used in the example). The router will transfer the request to UDP-Port 161 on the NetCom, which is the port for SNMP. The NetCom will answer the request, and send it out to your computer. The NAT function in the router will exchange the source IP of the data by its own public value, so the NetCom Manager will see the

answer come from the router. The NetCom Manager is satisfied with this data.

This answer brings every required information about the NetCom, including its internal IP-Address. Select the panel of NetCom Server Settings to verify the information, but do not make any changes here.

5.2.7.4. Serial Ports through SOHO Firewall

Now the NetCom is available in the NetCom Manager, but still the serial ports are not usable. The information of the TCP-ports for the VSrv related to the serial port is still missing. In the NetCom Server Settings select the NetCom Ports Panel. In this panel select one serial port, in this example of NetCom 113 there is only one serial port. Click the “Properties” button to open the configuration of the port.

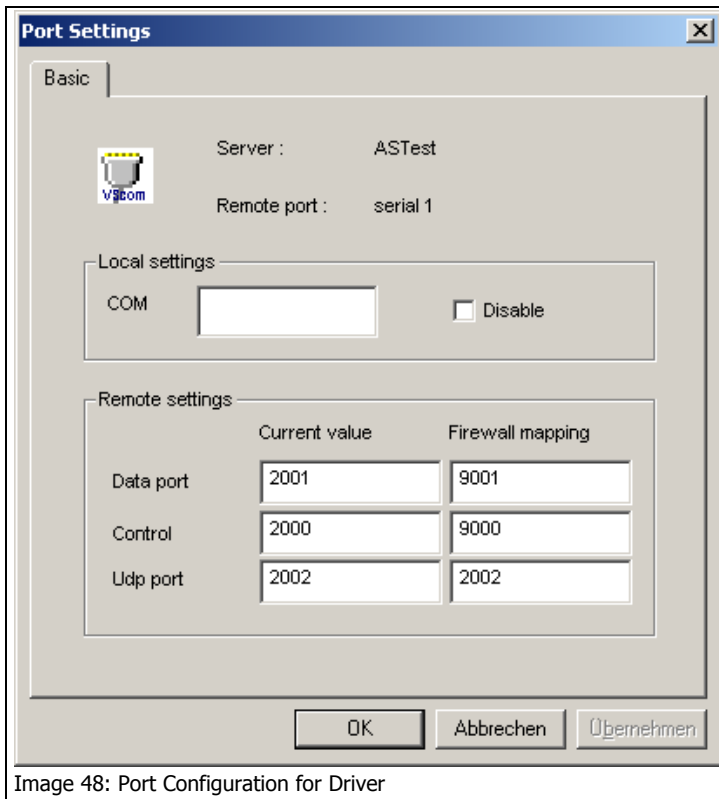

Image 48: Port Configuration for Driver

Since the Firewall function is enabled, the parameters for “Firewall mapping” are available for editing. Enter the ports defined in the router, 9001 and 9000 in this example. Please note, so far there is no number for the Virtual Com Port available. The driver is not installed in this

moment, and Windows does not know about the available hardware. This will happen later in the installation. Click the “OK” button, and proceed with the driver installation as already described.

5.2.7.5. DMZ and Virtual Servers

Why is it recommended not to use the DMZ function of the router? There are two reasons. The first one is simple, only one device in the LAN can be defined as the DMZ target. The DMZ is implemented as “Send all IP data targeted for the router to the DMZ station, as long as there is no specific rule for a different target”. When a second NetCom shall be installed on the LAN, the Virtual Servers have to be configured anyway. The second reason is the security. Using the DMZ the Firewall in the router becomes transparent. All data from outside is transferred to the LAN, including all malicious data.

5.3. CONFIGURE NETCOM VIA TELNET CONSOLE

There are many situations, when using the NetCom Manager program for Windows is not appropriate. And a graphical Webbrowser may also be unavailable. To enable configuration also in this situation, there is the Telnet option. It is preferred by many users.

To connect your Telnet session you need the IP-address of NetCom. Also you must be able to communicate with NetCom via IP. If you can send a PING to NetCom and receive an Echo, the configuration is fine. This requires a predefined NetCom, maybe via a DHCP server. You may also use the NetCom Manager Program (on a different computer) to find the IP-Address of the NetCom. Start your Telnet program, set it to use a terminal emulation of VT100. This is recommended, but VT52 is also possible. The Telnet session is closed by the NetCom, when no user input occurred for at least 3 minutes.

In your Telnet, establish a connection to the NetCom. If the configuration port is changed from the default 23 for Telnet, use this port. If the NetCom is password protected, you need to enter the password right now.

```
Please enter your password: █  
Image 49: Password protected Telnet option
```

When connected to NetCom you must define the type of terminal used.

```
Please choose your terminal type (1:VT100 2:VT52 [1]): 1  
Image 50: Open configuration menu
```

5.3.1. TELNET MAIN MENU

The configuration with Telnet is menu-driven.



This is the start point for configuration. “ServerConfig” has all options to configure the NetCom device itself, including the IP-Parameters to access it. “SerialPorts” defines settings related to the serial port. “Tools” has some utilities like PING or displays statistics. In “Exit” you may leave the menu or reboot the NetCom. At any time you can get a short hint by typing “H” for help.

5.3.2. SERVER CONFIGURATION MENU

5.3.2.1. Parameter

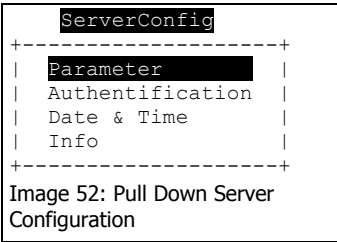

Selecting “Parameter” brings up all Network configuration items, listed below.

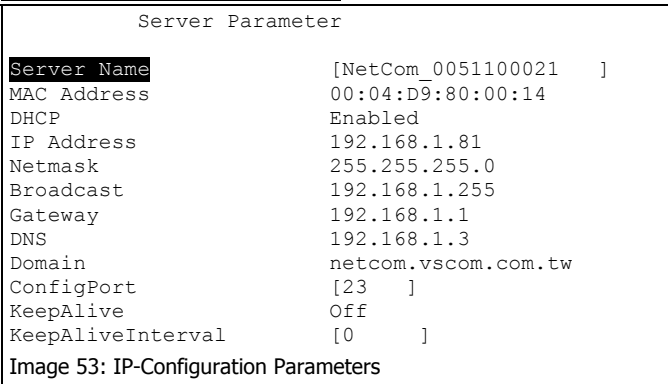

Use the cursors to select the parameter you want to change. Hit <Enter> to go in edit mode. Type the new value.

“Server Name” identifies the device when the driver software searches for devices; this will help you find the correct NetCom server.

DHCP is for automatic IP configuration. “IP Address”, “Netmask” and “Broadcast” are parameters you get from your network administrator. Same applies to “Gateway”, “DNS” and “Domain”. The “ConfigPort” is 23 by default, which is standard for Telnet. You should only change it if you have strong reasons.

”KeepAlive” is the TCP-intrinsic function of connection checking. The related interval is defined in seconds.

5.3.2.2. Authentication

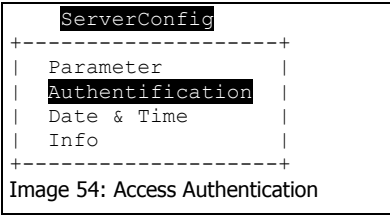

This menu allows to enter a password. This password is later required to get access to NetCom. It is also possible to leave the password empty.

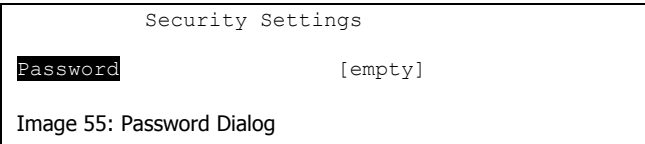

5.3.2.3. Date & Time

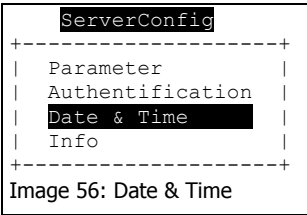

Since Firmware version 1.6 the NetCom can retrieve actual date and time from a specified server.

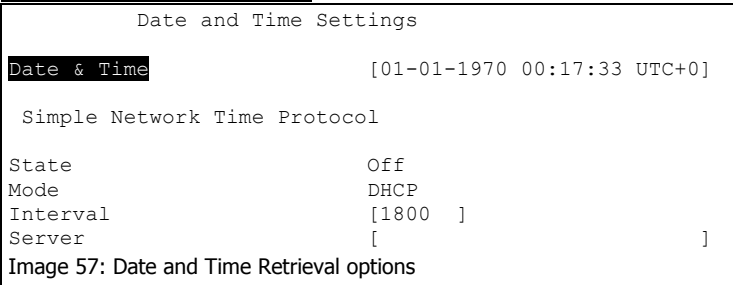

Retype the value of “Date & Time” for manual setting. The format is DD-MM-YYYY HH:MM:SS UTC+/-TZ (Time Zone)

The “State” field has three possible settings:

- “Off”: disables automatic time retrieval.
- “Startup”: NetCom gets the time at reset or power on.
- “Interval”: NetCom repeats to retrieve time.

The “Mode” field allows to decide how to configure the time server. It is either possible to get the server by DHCP, or direct specified. The “Interval” defines how often the NetCom retrieves the time from the “Server”.

5.3.2.4. Info

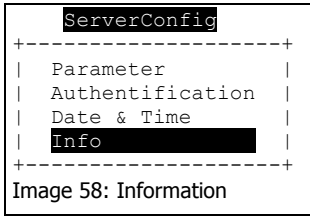

Info brings up general information about the device.

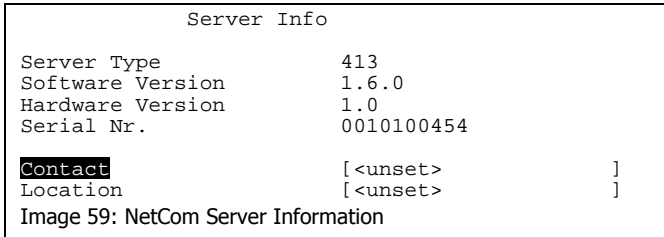

This dialog displays some basic information about the installed NetCom server. The Administrator may provide some contact information here. “Contact” defines a person to contact for help, e.g. “Mrs. Jane Doe, 555-HELP”. “Location” is the physical place of the NetCom, e.g. “CeBIT Hall 12, Service Box IX.a”.

5.3.3. SERIAL PORTS MENU

The settings available in this menu are by port. Therefore, first the port to configure has to be chosen.

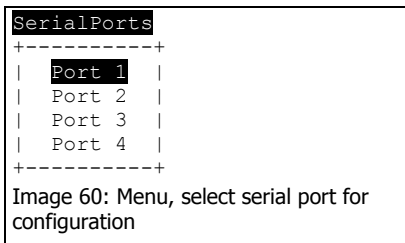

Just select the port by placing the cursor, and then press <Enter>.

5.3.3.1. Communication Parameters

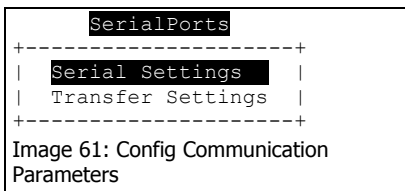

These settings come in effect in the case of the Raw connection type; i.e. if the Driver Mode is not used. The driver will configure the parameters as the application requested it.

The parameters are organised in two groups. The “serial settings” define the basic behaviour of the serial port. And the “Transfer Settings” configure the operation mode of NetCom on the network. Each serial port is configured separately, there is no setting shared between ports.

Serial Settings	
Port Nr.	1
PortType	rs232
MaxBaudrate	460800
Model	16550
Baudrate	38400
Manual	110
FlowType	None
DataBit	8
Parity	None
StopBit	1
RxFifoLength	2048
RxTriggerLevel	[1248]
TxFifoLength	2048
TxTriggerLevel	[800]

Image 62: Serial transfer parameters

Many standard options to use with all serial ports. The maximum serial speed is visible. You may configure the serial transmission by setting “Baudrate” from a defined list. If you select Manual in this list, you may enter it numeric below. If the selected value is not possible, an error is displayed. Also configure character size, parity mode and the length of the stop bit.

The settings of “RxTriggerLevel” and “TxTriggerlevel” define when NetCom issues a “buffer empty/full” message. If the values are less than 16, they have direct impact on the handling of the serial port hardware FIFO. Also, if you change the UART “Model” to 16450, the FIFO size is configured to support a single Byte. This option reduces latency times, by increasing the network traffic.

FlowType	+-----+
DataBit	None
Parity	RTS/CTS
StopBit	DTR/DSR
RxFifoLength	XON/XOFF
RxTriggerLevel	Advanced
TxFifoLength	+-----+

Image 63: Standard Flow Controls

FlowType opens a submenu of configurations. Handshaking is available via Standard XON/XOFF or RTS/CTS. Also possible is the use DTR/DSR. There is also an Advanced option for detailed and customer specific configuration.

FlowType Configuration	
Port Nr.	1
AutoCTS	off
AutoRTS	off
AutoDSR	off
AutoDTR	off
AutoTxXOnXOff	off
AutoRxXOnXOff	off

Image 64: Advanced Flow Control configuration

This Advanced allows to configure the flow control in a special menu. Every combination for incoming and outgoing flow control may be defined with this option.

5.3.3.2. Data Transfer Modes

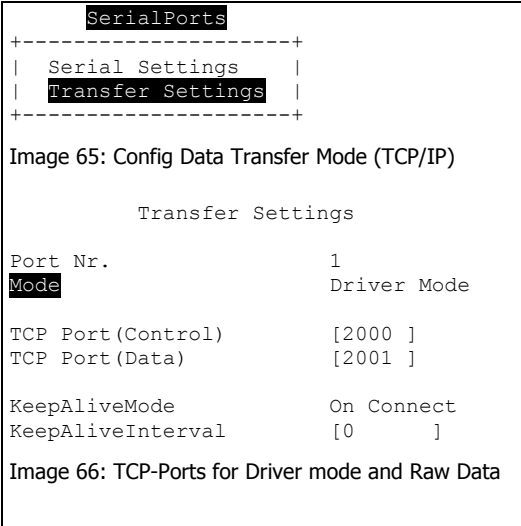

These are TCP/IP parameters. The TCP Port for “Data” transfers the serial data, while the TCP Port for “Control” transfers the control information defined by the VS NetCom driver, if installed. Programs operating in Raw TCP mode (like Telnet) connect to the “Data” port for data transfer. Since there are more transfer modes (listed below), all parameters are explained at the “Advanced Settings”.

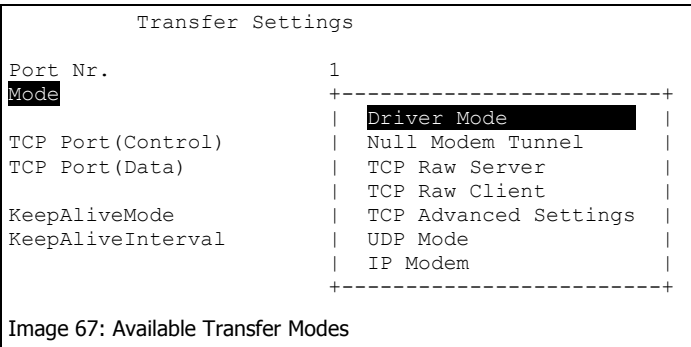

To change the current “Mode” of the serial port, place the cursor on the field and hit enter. A drop-down list of the available modes appears.

Transfer Settings	
Port Nr.	1
Mode	TCP Advanced Settings
Server	On
TCP Port (Control)	[2000]
TCP Port (Data)	[2001]
Max.Clients	[1]
Client	Off
Destination	[]
TCP Port (Control)	[2000]
TCP Port (Data)	[2001]
Connect	Triggered
ShortHoldTime	[0]
KeepAliveMode	On Connect
KeepAliveInterval	[0]

Image 68: Parameters for transfer modes

For demonstration purposes the “TCP Advanced Settings” mode is selected. All parameters may be changed. This allows some unexpected configurations. Here this is used to show and explain all parameters and their purposes. Information is also available On-Screen when typing help.

NetCom usually acts as a network server. This means it accepts incoming connections. The most used Driver Mode is explained above. It is possible to disable this option by setting “Server” to Off. Usually there is only one client connection at a time, but the limit can be raised.

NetCom can also operate as a network client, but in most installations it does not. This is enabled by setting “Client” to On. In certain situations NetCom contacts a computer (server) defined by “Destination” to send data. Most customers just need a Raw TCP connection to the server. The target application is defined by the “TCP Port(Data)”. If the server is another NetCom, both devices can also exchange control information via the “TCP Port(Control)”. There are three types of “Connect”, Permanent, Triggered and DSR. In Permanent mode NetCom connects to the server immediately. If the connection is interrupted for some reason NetCom keeps trying until it is established again. In Triggered mode NetCom connects to the server when data arrives on the serial port. When no more data arrives, “ShortHoldTime” (in milliseconds) defines how long to keep the connect before closing it. *Warning:* a time shorter than 1000 may cause problems. DSR is controlled by the external device via the DSR signal. When the DSR becomes active at the NetCom, the connection to the target is established. As long as DSR is active the NetCom operates similar to the Permanent configuration. When DSR becomes inactive, the connection is terminated.

NetCom can monitor an open connection. This is controlled by the “KeepAliveMode”, which has three settings: Off, On Connect and Polling. Please note, this option is effective only in Driver Mode and Null Modem Tunnel. If the Keep Alive function is required in the other modes, the global option in Server Parameters is available.

- o Off: no KeepAlives
- o On Connect: when a client is trying to connect to the server and there was a connection before, the server checks if the first connection still exists. If it does not exist anymore, the server accepts the new connection
- o Polling: the server checks in “KeepAliveInterval” (seconds), if a connection still exists.

There are predefined modes usable as compact configuration options. Listed and described below.

5.3.3.2.1. Driver Mode

In Driver Mode NetCom operates as a server. It accepts connections on the Data and the Control port. Both must origin on the same computer,

Mode	Driver Mode
TCP Port (Control)	[2000]
TCP Port (Data)	[2001]
KeepAliveMode	On Connect
KeepAliveInterval	[0]

Image 69: Driver Mode parameters

this is checked. The parameters for Keep Alive apply in driver mode. Only a single client computer is allowed at a time. The Control port set to zero is TCP Raw Server.

5.3.3.2.2. TCP Raw Server Mode

Mode	TCP Raw Server
TCP Port (Data)	[2001]
Max.Clients	[1]

Image 70: TCP Raw Server parameters

The NetCom also operates as a server in this mode. It only accepts raw data connections to the Data port (this is also possible in Driver Mode). In

Raw Server mode multiple clients may connect. Serial data received is sent to each client, all clients can send data. The customers application is responsible to avoid data confusion and damage.

5.3.3.2.3. TCP Raw Client Mode

Mode	TCP Raw Client
Destination	[]
TCP Port(Data)	[2001]
Connect	Triggered
ShortHoldTime	[0]
Image 71: TCP Raw Client parameters	

In Raw Client Mode the NetCom is a network client. Under defined conditions it establishes a Raw TCP connection to a

pre-defined "Destination". Since version 2.0 of the NetCom Firmware the Destination can hold multiple hosts as targets for a connection. They are entered as a comma separated list of DNS names or IP-Addresses. Each destination will have a TCP port number, separated by a colon. Instead of a single IP-Address or DNS name, a range of IP-Addresses is also valid. This range must be followed by the TCP port number, as in 192.168.254.12-192.168.254.17:2077.

The Connect modes and Short Hold Time apply.

5.3.3.2.4. Null Modem Tunnel

Mode	Null Modem Tunnel
Server	
TCP Port(Control)	[2000]
TCP Port(Data)	[2001]
Client	
Destination	[]
TCP Port(Control)	[2000]
TCP Port(Data)	[2001]
ShortHoldTime	[0]
KeepAliveMode	On Connect
KeepAliveInterval	[0]
Image 72: Null Modem Tunnel parameters	

This is a special mode. Two NetComs connect via network and simulate a long Null Modem cable between the two serial ports. This mode is symmetric, both NetCom operate as server and as client at the same time.

The server part operates in Driver Mode and waits for incoming connections. Serial data is transmitted, but also control and status signals on the serial port.

The client part uses the three types of "Connect", Permanent, Triggered and DSR.

5.3.3.2.5. IP Modem

The serial port of a NetCom may mimic (emulate) a serial modem. This feature is available since Firmware version 2.0 of the NetCom. There is the separate section **Fehler! Verweisquelle konnte nicht gefunden werden.** defining this functionality.

Mode	IP Modem
TCP Port(Data)	[2001]
Destination	[]
IP Modem Config	[]

Image 73: IP Modem Parameters

Here are the basic network parameters only. A modem accepts connections from the

network, in this case via TCP/IP. The TCP port for this is defined as the “TCP Port(Data)”. This is the only parameter required to set here. All other values are normally defined via AT-commands. However for short, “Destination” allows for up to four predefined targets, available with special Dial commands. The “IP Modem Config” is known as the Init String in standard modems.

5.3.3.2.6. UDP Mode

UDP is an Internet Protocol, which does not define a connection. There is no extra data to signal a successful transmission. As a side effect data may be sent and received faster than with TCP/IP. UDP is available since Firmware version 1.4.0

Transfer Settings	
Port Nr.	1
Mode	UDP Mode
UDP Port(Local)	[2002]
Destination	[]
UDP Port(Dest)	[2002]
UDP MaxPacketSize	[1458]
UDP Timeout	[0]
UDP Trigger	[]

Image 74: UDP Mode parameters

Please compare with the parameters for TCP Raw Server and Client Modes. The parameters to configure the UDP Mode are similar to a mixture of these modes.

Since there is no connection as in TCP/IP, it is required to configure the NetCom to receive data via UDP. The only parameter required is the local port number. To define where to send the data NetCom needs the Destination, and the port to address there. Since there is no connection, data can not be sent in a stream. UDP uses packages. There are several ways to define the content for a package. The maximum size of such a package may be defined. If this amount of serial data is received, a package is generated and sent. “UDP Timeout” (given in Milliseconds) is an interval. If no serial data

is received for this time, all data available so far is sent as a package. A value of zero causes all data to be sent immediately.

“UDP Trigger” defines a sequence of characters. As soon as this sequence is detected in the received data, all data up to the end of this Trigger is sent to the destination. In most situations such a Trigger includes control or other special characters. Enter them numeric: as \xHH where HH is the hexadecadic code of the character, or as \OOO where OOO is the octal code of the character. The backslash itself must be doubled as \\.

5.3.3.2.7. Print Server Function

Firmware Version 2.2 introduces the function as a Print Server according to RFC1179, also called a »Line printer daemon«. A print server is accessed through its IP Address via one specified TCP Port (see Parameter in 5.3.2 above). Data is handled in distinct queues, each with a certain name. Each queue is handled by a certain serial port, and the data is sent to the serial printer attached to this port.

Transfer Settings	
Port Nr.	1
Mode	Print Server
QueueName	[lpd1]
InitString	[]

Image 75: Telnet Print Server Configuration

Each serial port configured for Print Server operation has its separate “QueueName”. The default value is »lpd« plus port number. The “InitString” is a special feature of NetCom. This

string is sent to the serial printer at the beginning of the next queued print job. The definition is in section 8.2.2.1 below.

5.3.4. TOOLS MENU

5.3.4.1. Ping

Tools
-----+
Ping
Statistic
Netstat
Logging
Firmware
-----+

Image 76: Tools menu

The Ping tool allows for verification of network settings. Try to reach some hosts in your local network.

IP-Address to ping to:	[192.168.1.42]
------------------------	-----------------

Image 77: Ping test utility

5.3.4.2. Statistics

```
Tools
+-----+
| Ping   |
| Statistic |
| Netstat |
| Logging |
| Firmware |
+-----+
Image 78: Statistics for
serial ports

Tools
+-----+
| Port 1 |
| Port 2 |
| Port 3 |
| Port 4 |
+-----+
```

The Statistics are presented on a by-port base. So you first select the serial port, and then you have the information about modem status and control. Also the amount of data transferred is shown.

```
Line Status
DTR      off (0)
DSR      off (0)
RTS      off (0)
CTS      off (0)
DCD      off (0)
RI       off (0)

Common
Serial Tx      0
Serial Rx      0
```

Image 79: Status and Statistics

Netstat

Netstat is a common tool to display the actual status of network connections. It may be used to monitor the actual status of the NetCom.

```
Tools
+-----+
| Ping   |
| Statistic |
| Netstat |
| Logging |
| Firmware |
+-----+
Image 80: Netstat analysis
```

This is a sample result of Netstat. When there is more to display, it will start with “1/2” in the first line. Or even more for a long list. You may change to a different page by using the

```
1/1
Proto Local Address      Foreign Address    State
tcp    0.0.0.0:23         0.0.0.0:0         LISTEN
tcp    0.0.0.0:80         0.0.0.0:0         LISTEN
tcp    0.0.0.0:2000       0.0.0.0:0         LISTEN
tcp    0.0.0.0:2001       0.0.0.0:0         LISTEN
tcp    0.0.0.0:2010       0.0.0.0:0         LISTEN
tcp    0.0.0.0:2011       0.0.0.0:0         LISTEN
tcp    0.0.0.0:2020       0.0.0.0:0         LISTEN
tcp    0.0.0.0:2021       0.0.0.0:0         LISTEN
tcp    0.0.0.0:2030       0.0.0.0:0         LISTEN
tcp    0.0.0.0:2031       0.0.0.0:0         LISTEN
tcp    192.168.1.98:23   192.168.1.42:3665 ESTABLISHED
udp    0.0.0.0:161        0.0.0.0:0
udp    0.0.0.0:33320     0.0.0.0:0
udp    192.168.1.98:10397 0.0.0.0:0
```

Image 81: Sample Netstat output

Page Up/Down keys in your Telnet. The display is refreshed in an interval of some seconds. Use ESC key to return to the menu.

5.3.4.4. Logging

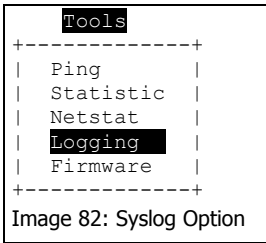

Since firmware version 1.6 the NetCom has two options of Logging. There is the standard Syslog, and a second option of logging via Telnet.

Activate the Syslog, and define the machine with the Syslog Demon running. Also configure the Facility parameter.

You may also connect to a special “Debug Port” on the NetCom to get all messages in realtime.

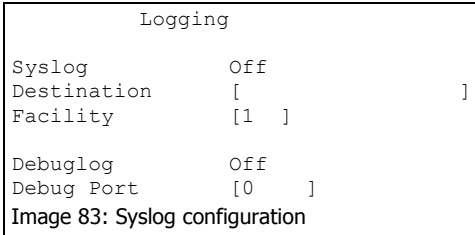

5.3.4.5. Firmware

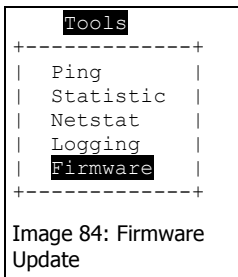

There is an option to upgrade the Firmware of NetCom. This is either done via the actual channel (i.e. the serial or Telnet connection). Or independently via a separate TCP/IP connection. This setting defines the parameter. The Firmware is sent coded in base64, via very simple programs like a second Telnet session, or similar tools.

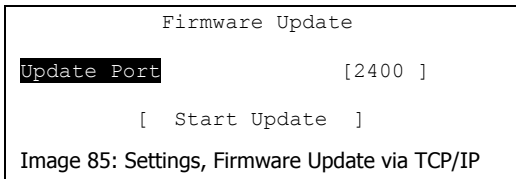

5.3.5. SAVE&EXIT MENU

5.3.5.1. Save Parameter

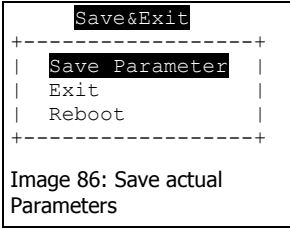

When some changes are done, it is possible to save these modified settings here. Confirmation is requested before doing this.

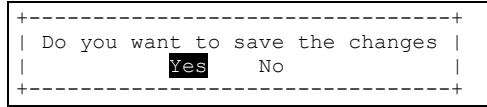

5.3.5.2. Exit

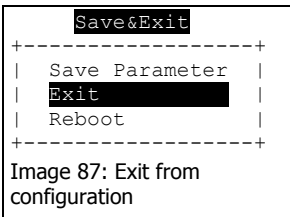

You will not be surprised, when you leave the menu by selecting this option. If you made any changes of parameters, you must confirm to save these.

5.3.5.3. Reboot

You also leave the menu here. But the NetCom is restarted. This activates any changes in the settings. This reboot is necessary for some changes like IP configuration. Others do not require a reboot. Also here, if parameters are changed during the session, confirmation for saving them is requested.

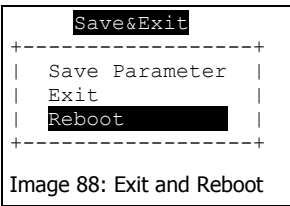

5.4. CONFIGURE NETCOM VIA SERIAL CONSOLE

In some situations it may be impossible to get network access to the NetCom Device. If this happens (e.g. by an accidentally misconfiguration), neither Telnet, nor the webinterface is functional. It may be even impossible to use the NetCom manager program.

In this case you must you must connect to the NetCom via the serial port. Disconnect any serial cable from NetCom. Set the DIP-Switches of port 1 to “RS-232 Configuration”, all switches to Off. Then connect the NetCom with your computer using a standard modem cable (direct connection). If you do not have a modem cable, use a Null Modem cable and plug the Null Modem adaptor to the serial port. On NetCom 211 or the rackmount versions you need a Null Modem cable anyway.

Open any serial terminal program (Hyperterminal, minicom, ...), select 38400 bps, 8 Bit, No Parity as configuration. Set your terminal to emulate a VT 100 (recommended, but VT52 is also possible), including the Arrow keys.

When connected to NetCom you must define the type of terminal used. This is the same configuration option as described above in 5.3.1 Telnet Main Menu.

6. THE VIRTUAL COM DRIVER

If properly configured, the serial ports of the NetCom Devices appear as virtual serial ports in your computer. The “virtual” means, there is no real hardware related to the serial port. However the driver offers the full functionality of a serial port to the system. The interface used by the driver is VCOMM, which in turn is supported by the Windows API. So Windows does not see a difference to Com1, and also no application should detect the change.

This section of the manual covers the correct installation of the drivers and serial ports. Please do a quick review of the section 4 Windows Driver Quick Installation, before reading further. As of the time of writing, the current driver is version 1.4.8.9

6.1. INSTALLATION OF NETCOM SERVERS

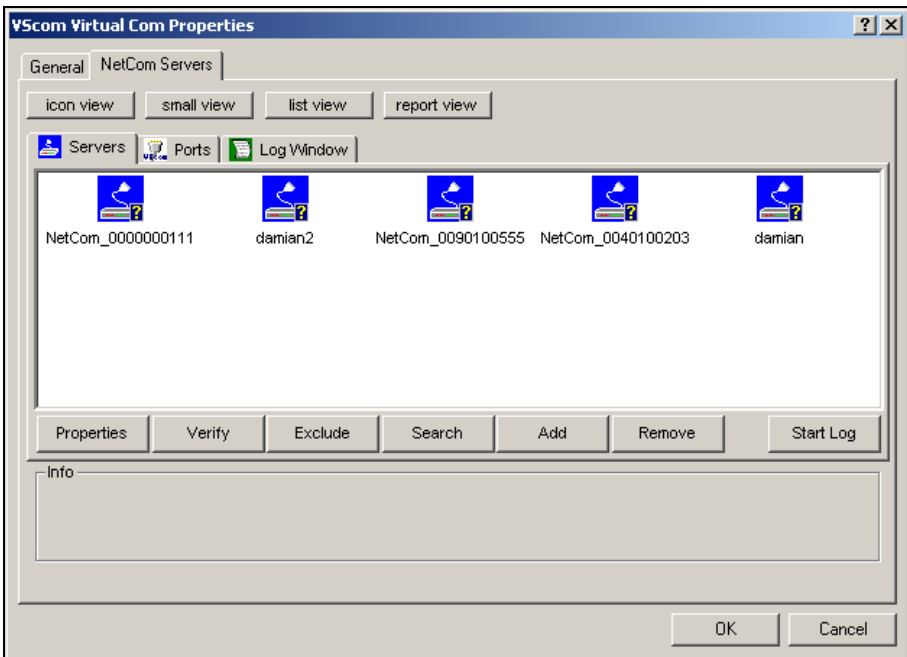

Image 89: Select NetCom to install

The NetCom Manager program is started by the Installation Wizard. Often there are more than only one NetCom listed. And sometimes not all of them are to be used on this specific computer.



NetCom_0090100555

Image 90:
Excluded NetCom

The “Exclude” button is used for that purpose. Select a NetCom Device, and click on that button. The driver will later ignore this NetCom, when installing and operating the serial ports. The Icon changes to olive color.

In “Image 89: Select NetCom to install” above you’ll notice yellow question marks at each icon. These appear when the NetCom is not already installed for the Virtual Com driver. It may also appear, if you open NetCom Manager without administrative privileges. If the mark changes to a red exclamation mark, the NetCom is non functional. It may be without power, the network may be broken, or the device is completely removed. To clear the display in NetCom Manager just use the “Remove” button.

If a NetCom has not been operational when the Manager program was started, it is either displayed with the exclamation mark, or not displayed at all. You may make it operational by connecting it now. To install it, use the button “Search” to find it in the network now. Or “Add” it manually with that button.

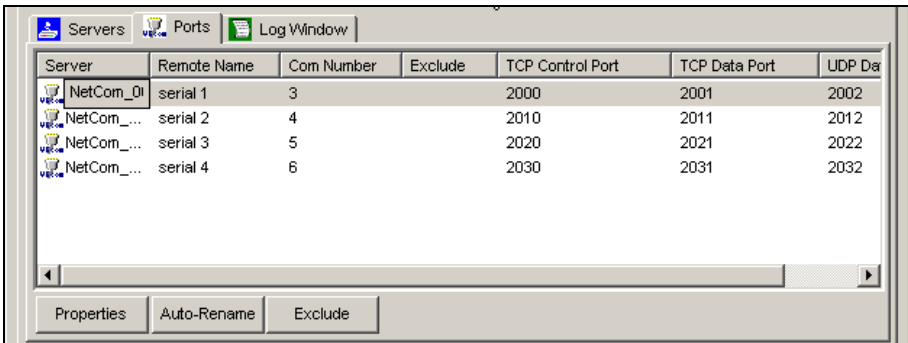

Image 91: NetCom Manager Ports View

Similarly you may exclude certain ports on a specific NetCom Server from installation as a Virtual Com port.

These are the special options used while installing the driver software. At any time after installation the configuration may be changed by the NetCom Manager program. This may result in serial ports appearing in or vanishing from the system.

6.1.1.CHANGING THE INSTALLATION

There are common situations, when the current configuration needs a change. In the first case the NetCom has been moved to a different location, or the logical structure of the network has changed. It may happen the IP-Address of NetCom is also changed. Either by Automatic (DHCP), or manually via a different interface like the Webbrowser. Because of the changed address the driver does not find the serial port to contact. Now open the NetCom Manager. It will re-detect the devices. In this process the Manager finds the already installed NetCom, but with a new configuration. Then the Manager requests

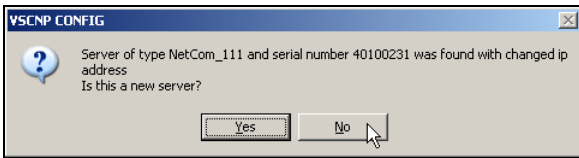

Image 92: Reconfigured NetCom found

interaction from the user. This question here assumes the NetCom shall be installed from scratch. This will produce a Com port with a new number. If just a reconfiguration occurred, click on "No". When you do that, the parameters of the installed Virtual Com are changed to contact the same serial ports on a new network address.

The second case occurs, when a NetCom is replaced by another device. This new device shall have the same configuration, especially the same IP-Address. When you start the NetCom Manager, it will detect a new device with parameters already in the database. So a similar question

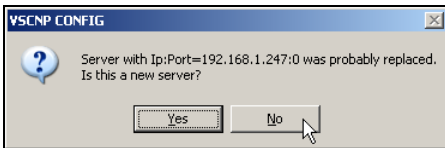

Image 93: Replaced NetCom found

appears. An installation of a new serial port is assumed again. If the device shall replace the old one, Click on the "No" button.

In general the driver software and the NetCom Manager identify the NetCom Devices by the combination of IP-Address and serial number. If one of these is changed, the above requests appear.

6.2. CONFIGURE THE SERIAL PORTS

When the serial ports are installed by the Virtual Com driver software, any application may use them. In the Device Manager they appear as “NetCom COM Port” (Image 8: NetCom in Device Manager). Without special tests a program does not see a difference between Com1 and virtual Com7. For example the HyperTerminal program has no problem to communicate through these Virtual Com. And this situation is common amongst most programs.

A typical application selects a serial port, and opens it. After that it performs the standard configuration of bits per character, parity settings and number of stop bits. Also the flow control (handshaking) is defined by the application. Windows sends these requests to the port driver, and this driver sends the requests to the serial port on the NetCom.

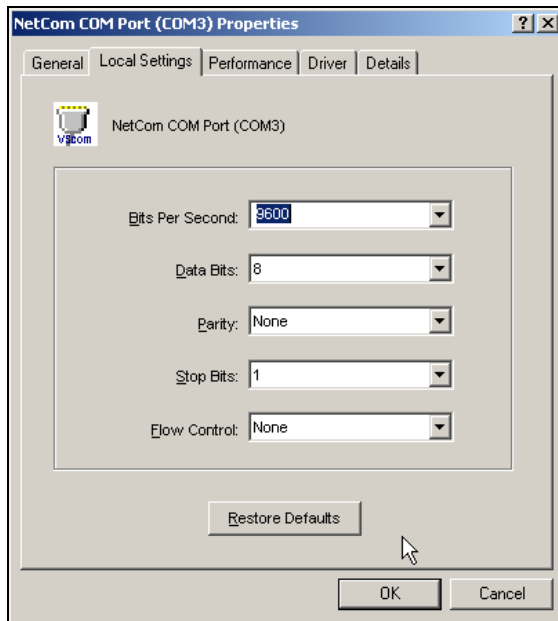

Image 94: NetCom COM Port Serial Settings

The same parameters may be pre-configured in the Device Manager. This is done via the “Properties” of the “NetCom COM Port”. In the “Local Settings” tab these standard parameters are defined. Since most programs configure these parameters by themselves, the values are very rarely used. A typical situation is a serial printer attached to this virtual port.

As usual this behaves different in Windows NT. There is no Device Manager. To change these standard parameters, open the “Ports” applet in the Control Panel.

However it is suggested you open the new “NetCom Manager” applet instead. Change to the “Ports” view as in Image 91: NetCom Manager Ports View. Double-click on the small icon at the left side. In this dialog go to the “Local Settings” tab, as seen above.

6.3. PERFORMANCE ISSUES

However operation through the network causes some extra time, which is approximately 5 Milliseconds. With a port internal to the computer this time may be just some 100 Microseconds. This has an impact on reaction times. Some data protocols may be sensible. A lot of configurations are possible to compensate for this. But these have an effect on the sheer data throughput of the virtual serial port.

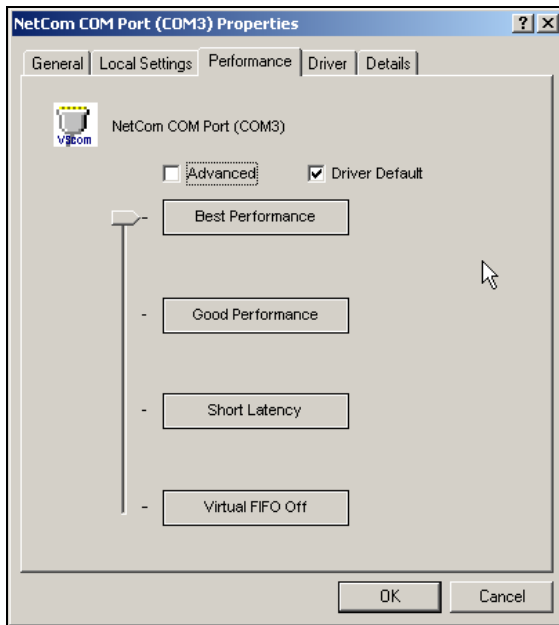

Image 95: NetCom COM Port Performance Settings

Consequently the configuration starts on the “Performance” tab. There are four already defined sets of parameters. The default configuration is for “Best Performance”. The driver software and the NetCom communicate with big data blocks. As a result a reaction on short events on the serial port is somehow delayed. For applications operating

with short data blocks, and waiting for short answers this is not optimal. It causes transmission delays, called Latency.

In three steps the Latency may be reduced, at the cost of reduced throughput for large data blocks. The fastest setting “Virtual FIFO Off” simulates a deactivated FIFO. The port is configured as if the FIFO is off, buffers are configured to never wait for a timeout, hence gaining in best reaction times. “Short Latency” mimics a 16C550 with full FIFO enabled, but no network timeouts will occur. Use the ”Driver Default” to get the standard setting.

Use “Advanced” to get access to detailed configuration.

6.4. NETWORK & MISC PROPERTIES

When you use the “Advanced” checkbox on the “Performance” tab, the “Network & Misc” tab opens automatically.

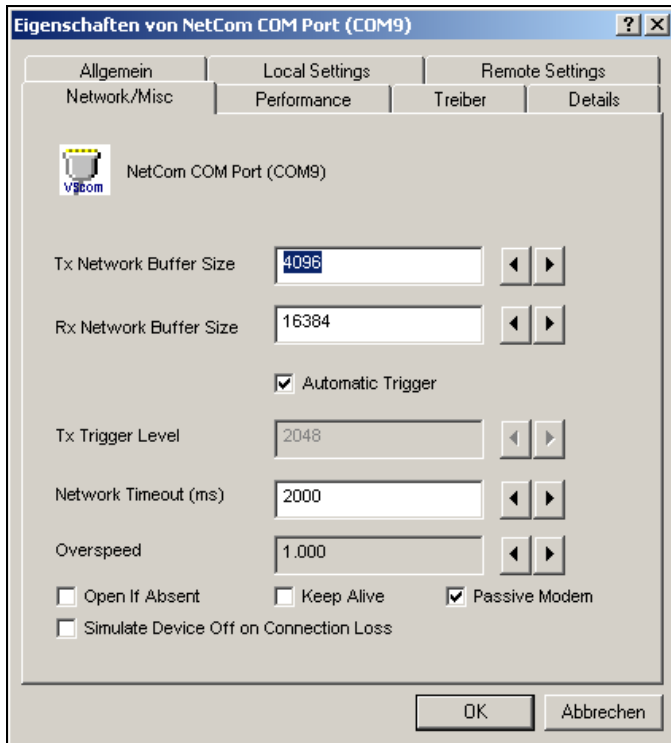

Image 96: NetCom COM Port Network & Misc Properties

The parameters on this tab control the operation of the driver software on the computer.

- “Tx Network Buffer Size”: If the application sends small chunks of data to the driver, these are buffered to send them in one large packet. This defines the size of the buffer. And also the maximum packet size sent to the serial port by the driver software.
- “Rx Network Buffer Size”: This is the size of the buffer to receive data from the NetCom.
- “Automatic Trigger”: based on internal rules, this checkbox selects a best practice value for “Tx Trigger Level”. Deactivate it to control that parameter manually.
- “Tx Trigger Level”: Controls the time when data is sent to the NetCom. If the Tx buffer holds at least this amount of data, the driver immediately sends them. If there is less data, the driver uses a timeout to determine when to send them.
- “Network Timeout (ms)”: This is the timeout.
- “Overspeed”: This is a special option, not really related to network communication. There are old applications, limited in the maximum speed. With Overspeed you define a multiplier. The baudrate requested by the application is multiplied with this factor. The result is sent to the NetCom to configure the serial port. E.g. the application may be limited to 38,400 bps, but there is a modem capable of 230,400 bps on the serial port. Set Overspeed to a value of 6.000, and configure the application to use 38,400 bps.
- “Open If Absent”: The NetCom may be used from a computer with a DialUp connection. When this option is used, the driver will delay the connection to NetComs serial port. Even when an application opens the port, and configures the parameters, no data is sent. The connection is established when data is sent to the NetCom, or when status information is requested.
- “Keep Alive”: This option will periodically send control information to the NetCom to check, if the connection is still operational. As a side effect a DialUp connection will not automatically close.
- “Passive Modem”: This option controls how often the driver retrieves Modem status information from the NetCom. If activated, the driver never asks for the modem status. Instead the NetCom informs the driver of any changes. If an application frequently requests the Modem status, it gets the last value received. On slow networks like the Internet this option is recommended.
If inactive, the driver software retrieves the Modem status from

the NetCom serial port each time the application requests it. With a maximum frequency of 10 per second. If the latest retrieved information is not older than 100 milliseconds, this value is returned.

“Simulate Device Off on Connection Loss”: When this option is enabled, the NetCom driver does not attempt to preserve transmitted data. If on a normal serial port the connected device is switched off, all data sent to this device gets lost. NetCom simulates this behaviour. All data sent from the application to the driver is discarded, when the TCP connection to the NetCom is lost. The NetCom attempts to re-establish the connection in regular intervals. When it is available again, data may be transferred from then on.

6.5. REMOTE SETTINGS PROPERTIES

The other panel created by activating the “Advanced” checkbox on the “Performance” tab, is the “Remote Settings” tab.

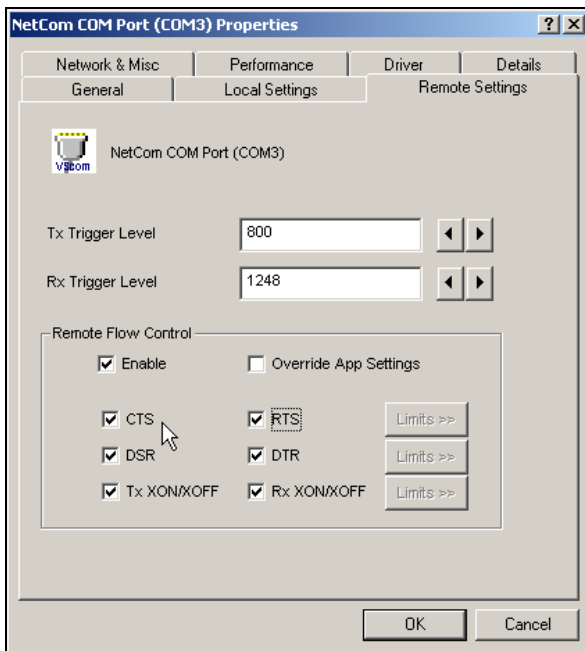

Image 97: NetCom COM Port Remote Settings Properties

The parameters on this tab control the operation of the serial port on the NetCom Device. They are defined and activated by the driver software.

“Tx Trigger Level”: The serial port on the NetCom Device buffers data for transmission to external devices. If the amount of data in this buffer drops below this level, the NetCom is capable to receive new data. It will send a related event to the driver software.

“Rx Trigger Level”: When the serial port has received this amount of data, these are sent to the driver on the connected computer. If the amount is less than this, the NetCom applies a timeout of about 5 character times. This means the timeout varies with the serial transmission speed.

“Remote Flow Control” signals the NetCom to perform the handshake on its own. This is necessary, because the network delay of some milliseconds is too long for reliable operation in many situations. To use this option, Firmware version 1.8.0 is required for the NetCom.

“Enable”: The configuration shown here is active, when the pre-defined performance levels are used. When using the “Advanced” option, Remote Flow Control is completely disabled. Enable as required.

While it is best practice to configure as above, you can disable certain events here. “CTS”, “DSR” and “Tx XON/XOFF” control the output of data to the serial port. And “RTS”, “DTR” and “Rx XON/XOFF” are used to stop transmission from the connected device. An application has the option to use any combination of these methods at the same time. The command to use them is transferred to the NetCom. For example, if the port is configured to use Hardware Flow Control, the NetCom will control the RTS line, and observe the CTS line. If requested, any of these methods may be unchecked. In that case the driver software on the computer will control the lines.

“Override App Settings”: In rare situations it is necessary to ignore the applications configuration. Check this box, and select the Flow Control to use with the device.

“Limits”: These buttons are prepared for future software versions.

7. UNINSTALLING THE SOFTWARE

The drivers and services install as usual. So it is easy to remove the drivers from the system. The entry is found in Control panel, section “Add/Remove Programs”. It is removed like other applications.

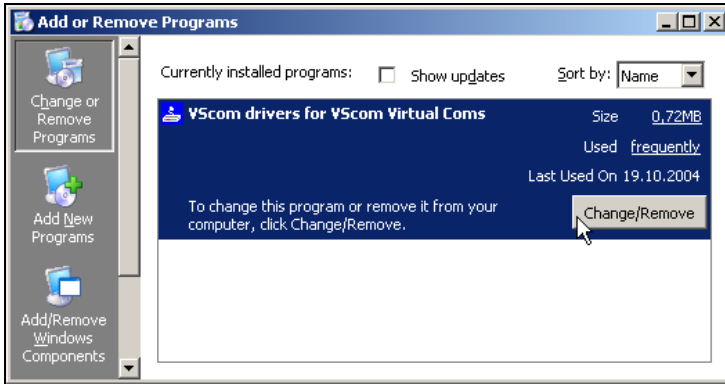

Image 98: To uninstall the NetCom software

You must confirm the uninstall operation and the devices are removed from the system. Further all driver and configuration files are removed from the Windows- and System-directories. A simple de-installation via the Device Manager may result in some driver files scattered in Windows.

There is also a separate uninstall item in the Start Menu. This is the same procedure as in the Control Panel. You are also asked to confirm the de-installation of the drivers.



Image 99: Uninstall in the Start Menu

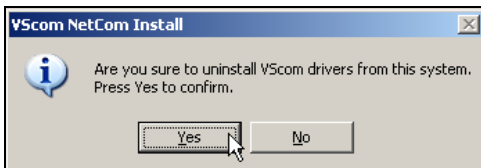

Image 100: Confirm Uninstall of Drivers

You may also start the Installation Wizard a second time. It will detect the installed drivers. The options are to Re-install the drivers, this is similar to a repair installation. And it is possible to completely uninstall the current drivers.



Image 101: Installation Wizard to uninstall Drivers

8. SPECIAL FUNCTIONALITIES

This chapter documents some functions and protocols, not directly related to the basic function of a serial port. There is the Modem Emulation by IP-Modem, the Print Server mode, and the encrypted communication by OpenVPN™.

The technical details of these operation modes are described in this separate section, because it would be too confusing to have the details in the description of the configuration menus.

8.1. IP MODEM FUNCTION

The Firmware version 2.0 brings the new function of IP Modem. Used in this mode, the serial port of the NetCom emulates a standard serial modem. Basically this means the NetCom will

- a) answer to AT-commands on the serial port
- b) establish a connection to a destination
- c) inform the connected serial device of the connection
- d) accept a TCP connection, and inform the serial device of that event

For connections the NetCom will use a TCP connection. This differs from a normal telephone line, so there will be some modifications in the behaviour. The target is an IP-Address, not a phone number. Also for hardware reasons the automatic baudrate detection used in today serial Modems is not available. However this is not a problem at all, the IP Modem can be installed in Windows as a Standard 33600bps Modem. Later there will be an INF-file for ease of installation.

8.1.1. SOME POSSIBLE SCENARIOS:

1. The customer has a remote management installation, operating via telephone line. These lines may be in-house or through public phone systems to other destinations. The customer wants to reduce costs for these lines, management and possibly hardware, using the Intra- or Internet.
2. The customer wants to contact several stations from a central server. Because of frequent target changes he does not want to define the target by a Virtual Com Port.
3. Remotely distributed devices contact a central system by Modem. This is the reverse of option 1.

4. A computer without Network access shall have at least limited control on the connections established by a NetCom.
5. Old fashioned BBS installations become accessible via Internet. The typical multi-modem box is replaced by a NetCom Server with multiple ports configured for IP Modem operation.

8.1.2. SERIAL SIGNALS AND CABLES

A real modem provides the same signals as the serial port of a PC. However, where a signal is an output on the PC, it is an input to the modem, and vice versa. So in the NetCom the emulation of a modem must be incomplete. By exchanging RxD and TxD the data connection is fine, the same for handshaking RTS and CTS. The DTR of the PC is connected to DSR of NetCom, this is simple. The RI may be ignored, some connectors for serial ports also do that.

However a real modem provides DSR and DCD to the PC. There is only the DTR left on NetCom to serve these signals. In most configurations the NetCom-DTR serves as the DCD to the computer. The cable must provide a DSR to the PC then, e.g. by shortcut to the PC-DTR. In some configurations the NetCom-DTR must serve as the DSR. This is configurable by a command.

The recommended cable connects as shown in this table. Please note, this installation does not use the simply crossed signals. Especially the DSR of the PC is internally connected to the DTR of the PC.

DB9m	PC		IP-Modem	DB9m	DB9f
3	TxD	-----	RxD	2	3
2	RxD	-----	TxD	3	2
7	RTS	-----	CTS	8	7
8	CTS	-----	RTS	7	8
6	DSR	PC-DTR (internal loop-back)			
4	DTR	-----	DSR	6	4
1	DCD	-----	DTR	4	6
5	GND	-----	GND	5	5

The limitation of signals is a restriction in function, compared to real world serial modems.

8.1.3. OPERATION MODES BY IP MODEM

The function of IP-Modem may be configured port by port. On a NetCom with a single port there is no much of a difference. However a NetCom with two or more serial ports operates each port independently. In the following sections of this manual the phrase “serial port of a NetCom, configured to operate as IP Modem” is replaced by “IP Modem” for brevity.

Two basic operation modes are available. The first and default mode is Modem-to-Modem. This requires a serial port of a NetCom configured as IP Modem on both ends of the connection. When one IP Modem dials the other, the connection is established on the TCP level. Directly afterwards both IP Modems negotiate to ensure, they are a real NetCom IP Modem and are free for connection. If successful both issue a “CONNECT ...” response to the serial connected devices. This is convenient for the customer to understand. The CONNECT may report some parameters, e.g. the minimum serial speed used by both Modems. These extra parameters are not implemented so far.

The other mode is named as Modem-to-Host. The destination is any software, which opens a TCP port for Listen. It may be a second NetCom configured for TCP Raw Server Mode. It may also be the customers application, running on a certain computer. This mode offers less features.

8.1.4. HAYES COMMANDS

The IP Modem operates with a command set similar to those in real Modems. All of the commands start with the character sequence **AT**.

8.1.4.1. AT command set

The following table lists many standard commands (in alphabetical order). The **AT** is omitted for brevity. The discussion of the functions is below the tables in section 8.1.5 below.

8.1.4.1.1. Standard AT-Commands

These commands are based on the old Hayes Modem

AT	Hayes-Standard	IP Modem Function
A	Answer Call	Accept a connection
Bn	ITU-T modulation	Define some modem operation modes
Dnnn	Dial connection, basically phone number as nnn	Connect to the target system by IP-Address and TCP-Port. E.g. ATD10,0,8,42,2023 will “dial” to port 2023 on IP-Address 10.0.8.42
E	Echo on/off	Enable/Disable local echo of command
H0	Hang up	Terminate the TCP connection.
I	Device Information	I0 through I9 report information
L	Speaker Volume	Ignored, always answered with OK
M	Speaker On/Off	Ignored, always answered with OK
N	Auto serial speed	N0 no Auto, N1 reports error
O	Return to data mode	
Q	Result Codes	Enable or disable result codes/strings
S=nm/S?	S-Register	Set/request configuration registers
V0/1	Responses	Numeric/text responses to commands
X	Busy/Dial detect	Ignored, always answered with OK
Z	Reset to User profile	Standard

Table 8: IP Modem Standard AT-Commands

8.1.4.1.2. Extended AT-Commands

AT	Standard-Extensions	IP Modem Function
&C	DCD control	When to turn on DCD (by IP-Modems DTR)
&D	DTR meaning	Hang Up, Command Mode or Reset
&F	Load factory Default	
&K	Flow Control	
&S	DSR control	When to turn on DSR (by IP-Modems DTR)
&V	View Profiles	
&W	Store Profile	&W0/&W1 is “Standard”. ATZ1 loads profile 1
&Zn=dd	Save for short dial	Define possible targets by DNS name or IP-Address

%C1	V.42bis enable	Ignored
\Q	Flow control	See &K

Table 9: IP Modem Extended AT-Commands

8.1.4.1.3. Non-AT commands

All these commands apply in Command Mode. If a Dial command succeeds with a CONNECT, the IP-Modem is in data mode. Every data received on the serial port is sent to the other station/IP Modem. And there is a special character sequence in Data Mode, which changes back to Command Mode. This sequence is +++ by default, with an interval of 1 second before and after this command; the three characters must appear in one second.

8.1.4.2. S-Registers for Configuration

Traditional there is a set of registers to control certain operations. These registers are controlled via the AT S-command mentioned above. This is a list of those supported by IP-Modem.

Reg.	Function	Range/units	Default
S0	Auto-Answer Ring	0-255	0 (no Auto-Answer)
S1	Ring Counter	0-255	0 (read only)
S2	Escape Code	0-127 (ASCII)	43 (= “+” for “+++”)
S3	Carriage Return	0-127	13
S4	Line feed	0-127	10
S5	Backspace	0-32, 127	8
S8	Comma pause	0-255 (seconds)	Accept but ignore
S9	Carrier detect response time	1-255 (0.1 sec)	6
S12	Escape Guard time	20-255 (0.02 sec)	50 (= 1 second)
S25	DTR Ready Delay	0-255 (0.01 sec)	5 (= 50 msecs)
S26	RTS to CTS Delay	0-255 (0.01 sec)	1 (= 10 msecs)
S30	Disconnect Timer	0-90 (seconds)	0 (read only, AT\Tnn)

Table 10: IP Modem S-Registers for Configuration

S0 is frequently used to configure a modem to auto answer incoming calls. S1 may be checked by software if S0 is Zero, i.e. no Auto-Answer. S2 may be set to a different character, if the “+++” may happen in typical data. Otherwise the software must insert a pause in the transmission.

8.1.4.3. Sample Commands used by Windows

The NetCom IP Modem is intended for manual installation as kind of a “Standard Modem” in Windows. The reference is the MDMGEN.INF file. The commands used in that file are:

```
"AT&F", "ATA", "ATH",  
"AT &F E0 V1 &C1 &D2 S95=47 S0=0<cr>", "ATS0=0<cr>",  
"ATX4", "ATS7=<#>", "AT%C", "AT\N", "AT&K", "ATS30=<#>",  
"ATB", "ATDP", "ATDT", "ATL", "ATM"
```

8.1.5. DESCRIPTION OF AT-COMMANDS

The commands are listed more or less in a functional grouping. Configuration commands are listed also with their default settings in brackets.

8.1.5.1. AT D (dial)

This is the general Dial command. The target is defined as IP-Address plus TCP-port number. The dots in the address are replaced by a comma, and the TCP port is also separated by a comma. On normal modems a comma generates a pause in the dialling sequence. This is commonly required, so all software will support it; even multiple comma.

The modifiers “T” for Touch Tone and “P” for Pulse dialling have no direct equivalent on the TCP connection. They are used to change between Modem and Host mode, if the **ATB** command enables this (**ATB2** or **ATB3**). Otherwise the IP Modem will ignore them.

Basically dialling is done to a given IP-Address plus a TCP port number. The IP-Address is given in decimal Octet format, where comma replaces the dot as the separator. This is followed by another comma, separating the TCP Port from the IP-Address. If the port is omitted, the target port is the same as the local TCP Data Port as defined in the configuration of IP Modem (see 5.1.2.2.5 or 5.3.3.2.5 above).

There are situations where the target is known by a DNS name. This name can not be used in a dial string, mostly because very few software will support it. So there is the option of dialling to a pre-defined entry by shortcut. This is given by an “S” followed by one or two digits. The shortcuts S90 to S99 are reserved; so far only S1 to S4 are implemented. Shortcuts are defined and saved by **AT&Znn=<FDN:Port>**.

All other non-numeric characters are understood as modifiers. The IP-Modem will simply ignore them. This especially applies to space characters. Typically dial strings are:

ATDT192,168,254,254,2003<cr>	Dial another IP Modem as a Modem-to-Modem
AT&Z12=demokit.vsc.com.tw:23<cr>	Define a shortcut for configuration port
ATDPS12<cr>	Dial the other IP Modem as Modem-to-Host

8.1.5.2. AT O (online / data mode)

If a connection is established, the IP Modem can still be in command mode. The **ATO** activates the transparent data mode.

8.1.5.3. AT A (answer call)

Have the IP Modem answer an incoming call, and establish a TCP connection. This command is required if Auto-Answer is disabled. Observe the operation mode defined by **ATB**.

8.1.5.4. AT B (modulation) [ATB1]

This command is used to define the modulation to use on the phone line. Since the only “modulation” available is IP, there is no choice. The command is used to change between Modem-to-Modem and Modem-to-Host mode.

ATB0	Modem-to-Host mode
ATB1	Modem-to-Modem mode, which is the default
ATB2	Modem-to-Modem when Touch Tone dialling, Modem-to-Host when Pulse dialling. Answer in Modem-to-Modem.
ATB3	Modem-to-Modem when Touch Tone dialling, Modem-to-Host when Pulse dialling. Answer in Modem-to-Host.

8.1.5.5. AT E (echo) [ATE1]

Disable and enable the echo of the commands received. **ATE0** to disable and **ATE1** to enable the echo.

8.1.5.6. AT Q (quiet) [ATQ0]

Configures the Modem to remain quiet. The Modem will not send any response messages to the serial port.

8.1.5.7. AT V (verbose) [ATV1]

Responses as numeric values (**ATV0**) or as text strings (**ATV1**).

OK	0	CONNECT	1
RING	2	NO CARRIER	3
ERROR	4	CONNECT 1200	5
NO DIALTONE	6	BUSY	7
NO ANSWER	8		

8.1.5.8. AT H (hangup) [ATH0]

Command to disconnect. Also used as **ATH0**. The related version **ATH1** to just go off-hook is not supported, and reports an ERROR.

8.1.5.9. AT I(n) (information) [ATI0]

Report technical information about the IP-Modem. It is frequently used to identify the device. The answer is always sent as `<cr><lf><#response#><cr><lf>` `<cr><lf>OK<cr><lf>`. Here are the defined `#response#`-strings.

ATI or ATI0	230	230.4kbps maximum
ATI1	100000000	100Mbps Ethernet
ATI2		
ATI3	Version 1.0 / <code><compile-date></code>	Version of Modem-Firmware
ATI4	Current Profile	
ATI5		
ATI6	NetCom 230k IP-Modem	Device Identification
ATI7		
ATI8		
ATI9	<code>(<Name>\Serial#\IP-#:port\Com-X\NetCom)</code>	Display serial port used
ATI10		
ATI11	<code><very extended information></code>	

8.1.5.10. AT S (setup)

Set and read the S-registers for configuration. **ATSrr?** is a request to read the current value, **ATSrr=nnn** stores the value nnn in the register rr. Unknown registers report ERROR. See Section 8.1.4.2 above for possible registers and parameters.

8.1.5.11. AT L (loudness)

8.1.5.12. AT M (speaker)

These commands are answered with OK, but completely ignored. There is no function like speaker.

8.1.5.13. AT N (auto baud) ATN0

Automatic detection of serial speed. For hardware reasons this detection is not implemented. The command **ATN0** is accepted and answered with OK. The **ATN1** for automatic detection is not available, and answered with the ERROR response.

8.1.5.14. AT Z (reset)

Reset the configuration to a stored profile. IP Modem only supports profile **0** for simplicity. Same as **ATZ0** or as **AT&F** or **AT&F0**.

8.1.5.15. AT &F (factory settings) [AT&F0]

This command has been designed as “Reset to Factory settings”, while **ATZ** simply meant reset. At time of invention users could change the default behaviour of their Modem, which was activated by **ATZ**. Nowadays the **ATZ** is ignored by many software. Instead **AT&F** is used, followed by complex initialisation strings. User may save profiles, which are selected by **AT&F0** or **AT&F1**. There is no longer a documented way to revert to Factory Defaults.

While IP Modem itself has such a way, this is not usable to simply reset the configuration as Modem. So IP Modem will support only user profile **0**, and it uses **AT&F9** to really reset the user profile to the Factory defaults.

8.1.5.16. AT &C (DCD configuration) [AT&C1]

Configure the DCD signal to the PC. As IP Modem this signal may be generated by the DTR output. A standard modem can have DCD always on, and it can have the DCD follow the external carrier signal. When set to always on by **AT&C0** the DCD may have a separate source. The DTR is free to serve as a DSR to the PC. The operation of DSR is defined by **AT&S**, so these commands are related. An **AT&C1** is the default, the DTR operates as DCD to the PC (this will require a cable connecting NetCom DTR to the DCD of the PC).

This command has priority over **AT&S**.

8.1.5.17. AT &S (DSR configuration) [AT&S0]

Configure the DSR signal to the PC. As IP Modem this signal may be generated by the DTR output. A standard modem can have DSR always on, as long as the Modem has power. Or it can have the DSR signalling whether the IP Modem is in command or in data mode. When set to

always on by **AT&S0** (this is the default) the DSR may have a separate source. The DTR is free to serve as a DCD to the PC. The operation of DCD is defined by **AT&C**, so these commands are related. An **AT&S1** has DSR follow the data mode.

The **AT&C** has priority over this command. **AT&S1** can only be effective, if **AT&C0** is set.

8.1.5.18. AT &D (DTR configuration) [AT&D2]

Understand the DTR signal of the PC. The input on the IP Modem is the DSR, which requires a proper serial cable. Usually this signal is either ignored, or serves to disconnect from the phone line. There are four options:

AT&D0	Ignore DTR from PC	
AT&D1	Toggle DTR to enter command mode	
AT&D2	Toggle DTR to disconnect and enter command mode	default
AT&D3	Toggle DTR to reset the IP Modem	perform ATZ

8.1.5.19. AT &K (handshake) [AT&K3]

AT \Q [AT\Q3]

Configure serial Flow Control. **AT&K0** and **AT\Q0** disable all Flow Control. The default is **AT&K3** and **AT\Q3** to use RTS/CTS Hardware Flow Control between PC and IP Modem. **AT&K4** and **AT\Q1** configure for XON/XOFF Software Flow Control between PC and IP Modem. Other Options are not supported.

8.1.5.20. AT &V (view profile)

Show Profiles. This will display the current profile, the stored user profile, the short dial strings and the factory profile. Parameters are accepted but ignored. **AT&V** is **AT&V0** and is **AT&V1**.

8.1.5.21. AT &W (save profile)

Save the current configuration as user profile. **AT&W** is the same as **AT&W0**, all other commands report an ERROR.

8.1.5.22. AT &Z (save destination)

This command will save a destination in internet syntax. It is given by <host>:<port>. The <host> is either an IP-Address in dotted octet notation, or an FQN in correct syntax. The <port> is a string representing a decimal number. If <port> is omitted, the target port is the local TCP Data Port as defined in the configuration of NetCom (see 5.1.2.2.5 and 5.3.3.2.5 above).

8.2. PRINT SERVER OPERATION

Sometimes the NetCom Serial Device Servers are used together with serial printers. These printers are available via a network to several stations for printing. So far there have been two operation modes to achieve this. First the serial port can operate as a TCP Raw Server, and the station just sends the data to print via a TCP connection. As second option a computer running Windows could install the driver for virtual serial ports. The printer is then controlled via this Com port. In both these solutions the buffering of data occurred on the client station.

Beginning with Firmware Version 2.2 the NetCom Devices offer a true Print Server mode, using the Line Printer Daemon protocol as of RFC1197. Here a print server (lpd) is a station with one IP Address and a single defined port to accept commands and data for printing. Several printers may be attached to the print server. Each printer has a separate data queue for management of print jobs. The data of the jobs is saved in this queue, instead of the client as before.

8.2.1. PRINTER QUEUE

The basic function of an lpd is to accept the data for printing, store it in a spooler queue, and send it to the printer when this is ready for printing. This is done for several queues in parallel. Each printer is identified by the name of the queue, where it is attached to. The NetCom Device Servers allow to configure a custom name for each queue, while the default name is »lpd« plus the number of the serial port (lpd1, lpd2, ...). This name is set in the properties of the serial port. When the lpd is running on a separate computer, the hard disk is used to save the data of the queues. The NetCom Servers neither have a mass storage device, nor huge amounts of memory. Each queue accepts at least one job with a size of up to 250 KB print data. If the job has more data, memory is either assigned dynamically to save the job, or the data is spooled through a ring buffer. Data is printed while the client still sends data. The amount of available dynamic memory depends on the number of ports in a NetCom Device Server, and the operations active on these ports.

8.2.2. PRINTER RESET

Before a new job is sent to the printer, this printer should be in a well known state. On a parallel printer port this is easy to achieve. There is a defined signal to send a »reset« command to the printer.

Such a definition is not available for serial printers. Instead there is a reset command, which users may send via the serial line. Typically this command is specific to the manufacturer or even to the printer model. So the NetCom allows to specify this command by entering an “InitString” for each queue.

8.2.2.1. Init String Definition

The Initialisation of the printer typically involves ASCII control codes, ordinary ASCII characters and some binary data. On some models it may also be necessary to provide a certain state of the modem control signals RTS and DTR, applied with special timing. The “InitString” in the NetCom Device Serves offer all these options.

8.2.2.1.1. ASCII Text

Ordinary ASCII characters are entered as they are on the keyboard. The single exception is the ‘Less Than’ character ‘<’, which is used for other special functions.

8.2.2.1.2. ASCII Control Codes

ASCII control codes are entered by their standard name, enclosed in ‘Angle Brackets’, i.e. in ‘<’ and ‘>’ (Greater Than). Some examples of this are <ESC>, <CR> or <TAB>.

8.2.2.1.3. Numeric Codes

Especially binary data must be send by means of its numeric value. Since the ‘<’ ASCII character has a special function, the only way to use this is the numeric method. This also applies to printable characters of some Extended ASCII character sets.

The NetCom accept the decimal value, also enclosed in angle brackets. Up to three decimal digits define the character to send to the printer. The ‘<’ is used as <60>, while the <ESC> may also sent as <027>. The ‘>’ may be used directly, however for clarity <62> should be preferred.

8.2.2.1.4. Modem Control Signals

Via the “InitString” control of RTS and DTR is available. This manual does not make statements about voltage levels on the signals, these are just set to an active or inactive state. <RTS+> and <RTS-> activate and deactivate the RTS signal, while <DTR+> and <DTR-> do the same for DTR.

8.2.2.1.5. Timing Options

Especially when using Modem Control signals it will be required to hold them in a given state for a defined amount of time. This may be done by applying a »Pause«-command in the “InitString”. The delay is given as numeric value in milliseconds (msec), preceded by a ‘P’. So

<P50> causes the NetCom to wait 50 msec before proceeding with the next command or start printing. Up to three digits are possible. If more than 999 msec are required, the Pause-command must be repeated. Please note: The delay is not executed as an exact time. NetCom guarantees to wait at least the required amount of time. The smallest delay possible is 10 msec, due to internal handling of date and time.

8.2.2.2. Reset Example

For example here is a hypothetical serial printer. The serial port operates at 1200 bps, 7 bit and even parity and 1 stop bit. For Reset the printer requires the command “<ESC>@0” sent with DTR and RTS off. When the data is transmitted, DTR must be on, and 50 msec later RTS must also be on.

Each character sent is 10 bits long, including the start bit. At 1200 bps each character needs 8.3 msec for transmission. So the transmission lasts for 25 msec. To be sure the control signals are active, an extra delay is applied after change of signals. The resulting string would be

<RTS-><DTR-><P10><ESC>@0<P35><RTS+><P50><DTR+>

The delay of 35 msec after the command data shall ensure, all data is completely transmitted to the printer.

8.2.3. OPERATION IN WINDOWS®

The Printer Server mode may be used to support serial printers in Windows® Operating System. This is a short instruction how to install and use it. Experience on installing printers in Windows is required for this instruction. First the installation of a new printer is given, the modification of an existing printer setup is described later.

8.2.3.1. Add a New Printer

From »Control Panel« open the »Printers and Faxes« windows. Select the »Add a printer« option. The usual »Add Printer« Wizard appears. Click the “Next” button to select the port, where the printer is attached to.

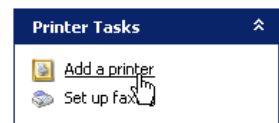

Image 102: Add a printer

Select the option of »Local Printer ...«, but de-select the automatic detection of the printer type as shown below.

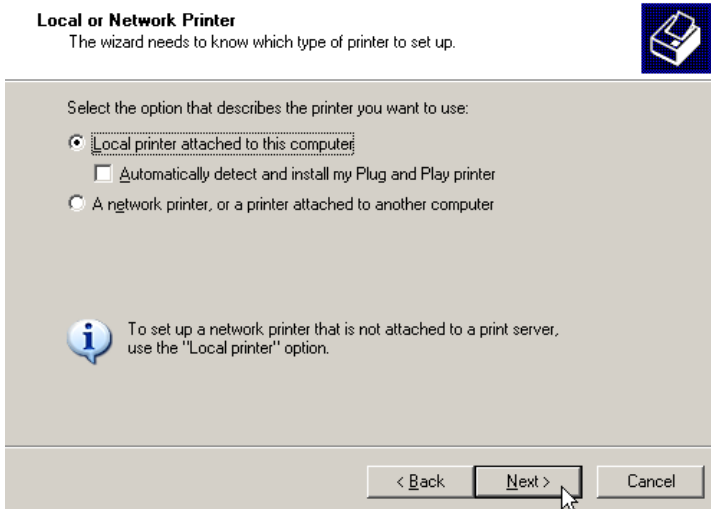

Image 103: Select Printer Port

Click the “Next” button to continue.

8.2.3.1.1. Create new printer port

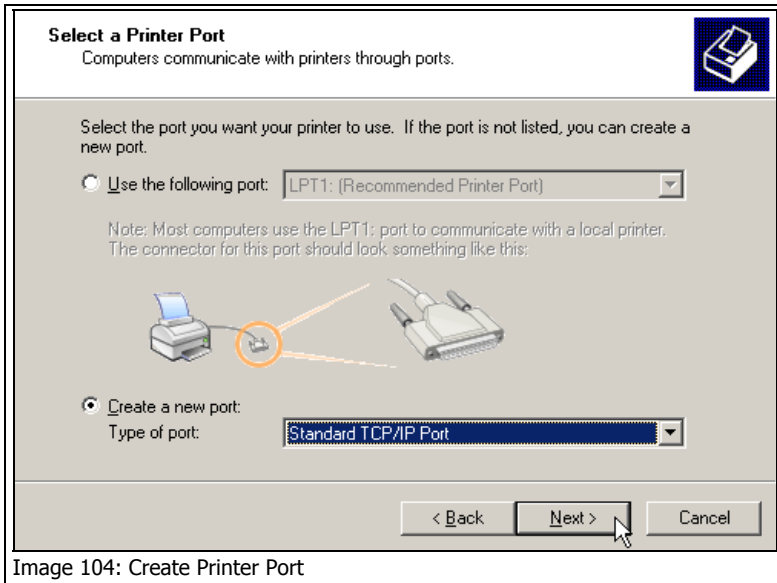

Image 104: Create Printer Port

You need to create a new port for the printer, the required type is a »Standard TCP/IP Port«.

In the »Add Standard TCP/IP Port« Wizard just click the “Next” button, and have the NetCom serial Device Server properly configured for LPD-operation.

8.2.3.1.2. Name the new Printer Port

Then the properties of the new printer port must be entered. You need the network address of the NetCom, this may be the IP Address or a DNS name for the device. The port name is only for internal identification in Windows. It will be listed in the possible ports to

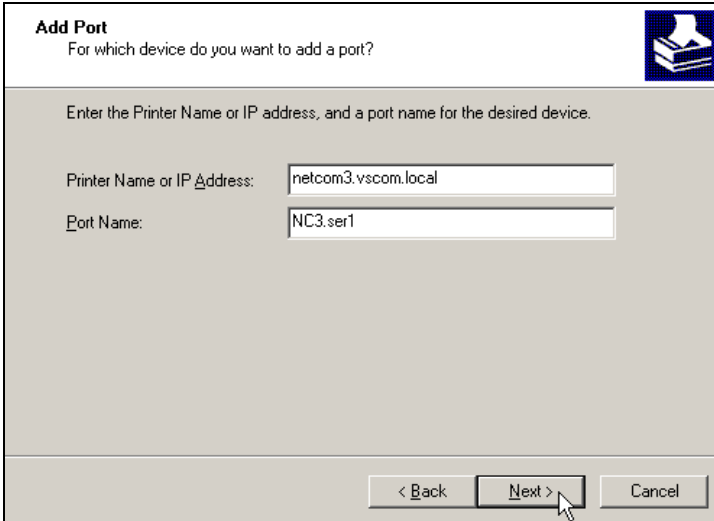

Image 105: Properties of Print Server Port

connect printers to. The name is similar to »LPT1:« or »Com3:«, but it does not denote any real hardware in your computer. You are free to enter any name not used so far. The name is not related to the LPD Queue name on the NetCom. Again click the “Next” button.

8.2.3.1.3. Configure the Printer Port

As the last step in creating the printer port for your printer you need to enter some additional information. As the »Device Type« select “Custom”, and open the “Settings ...”.

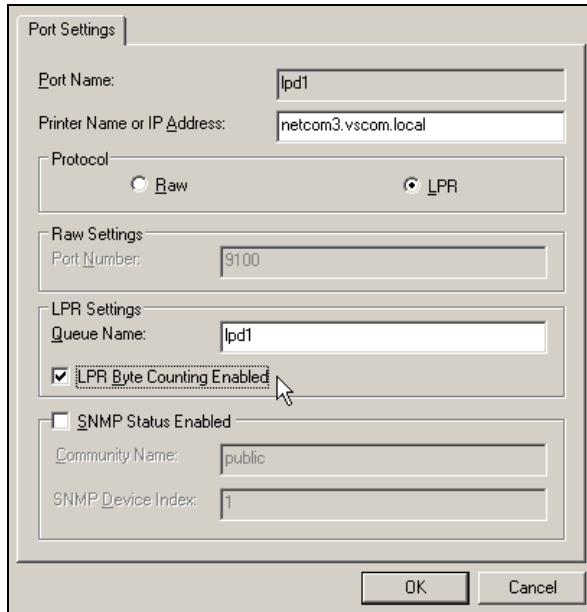

Image 106: Properties of Print Server Port

Under »Port Settings« select the “LPR” protocol instead of the “Raw” method. The Port Number becomes unavailable, because the standard TCP Port 515 is used in this configuration. Enter the Queue name you configured in the NetCom. Each serial port on a NetCom has a separate Queue name to identify it. So it may be a good idea to name the queue after the printer attached to the serial port. Be sure to enable the “Byte Counting”, because this is required by the Print Server function in the NetCom. Close these options with the “OK” button.

8.2.3.1.4. Install Printer Driver

Now the printer port is installed, and the Printer installation Wizard continues. Select the printer from the list, or install a new type using an installation disk the usual way.

8.2.3.2. Modify an Existing Printer

In several situations it is necessary to modify the configuration of a printer, which is already installed in Windows. For example, the mode of use shall be changed to Printer Server Mode, the printer is moved from a local serial port to a NetCom Serial Device Server, or the installation program of the printer only accepts local serial ports to attach the printer to. In such situations it is required to create a new lpd port, and modify the configuration of the printer.

8.2.3.2.1. Open the properties

Again open »Printers and Faxes« in the Control Panel. Select the installed printer, and open the properties.

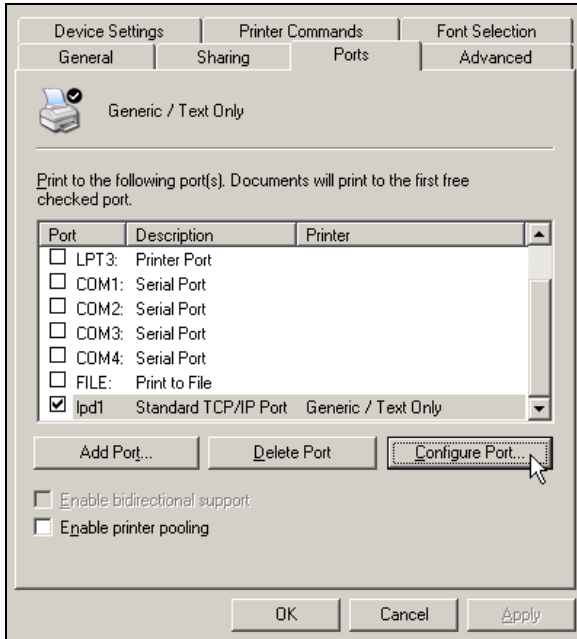

Image 107: Printer Port Properties

In the properties select the tab for »Ports«.

8.2.3.2.2. Add the Print Server Port

The button for “Add Port...” opens a dialogue with the possible printer port types. Select “Standard TCP/IP Port” and click on “New Port...”.

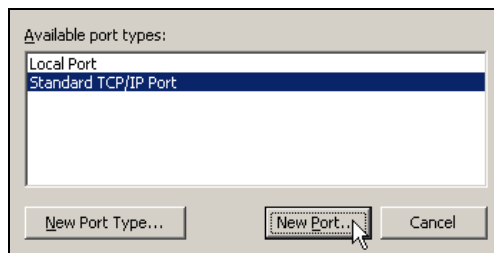

Image 108: Add Printer Port

This will open the Add TCP Port wizard as of section 8.2.3.1.2 above. Proceed as described there.

9. TCP/IP DESCRIPTION

TCP/IP is the protocol used on the Internet. Nowadays it is also used in local networks. This opens access to any device connected somewhere to the Internet. But a simple contact like plugging in a cable is not enough. The network has to be configured. Your network administrator is responsible to do that. If any question during configuration, ask him. Configuration means to set certain parameters in any device and computer.

Since IP-configuration is a frequent source of problems, a little bit of theory is provided here.

9.1. RECOMMENDED SETTINGS

Basically every device on the LAN has a so-called IP-address. In typical small networks the IP-address is similar to 192.168.X.Y, and there is a corresponding netmask of 255.255.255.0. The X ranges from 0 to 255, while Y is from 1 to 254. The combination of X.Y must be unique in your LAN, i.e. two stations must not have the same configuration.

9.1.1.STATIC CONFIGURATION

All stations on the network have a fixed IP-Address. In small networks this is typically of the 192.168-type. To configure NetCom for your LAN, it must have the same 192.168.X as your computer, and the same netmask. So it needs a unique Y to establish communication.

9.1.2.DHCP CONFIGURATION

Another typical configuration is the automatic configuration. This requires a dedicated server in the LAN, which serves as a so-called DHCP server. Every device can send a request, the reply is a special configuration for this device on the network. The NetCom Devices support DHCP, so just activate it.

For best operation the DHCP server itself should be configured. It may identify the NetCom Device by its MAC- or Ethernet-Address. There should be an internal database, to always provide the same IP-Address to stations with a given MAC.

There are free DHCP server programs available for Windows operating system.

9.1.3.AUTOMATIC CONFIGURATION (APIPA)

A different type of automatic configuration is used by Windows. If the stations are prepared for automatic settings, it will search for a DHCP server (see above). But in SOHO networks this server might not exist. Windows detects this failure, and the computer self-assigns an IP-Address. This address is from the reserved LINKLOCAL block for such purposes. The IP-Address is like 169.254.N.N, where N.N is from 0.1 to 255.254; the corresponding netmask 255.255.0.0 is mandatory. The address is selected by random, and checked if already used.

The NetCom Devices do not support this method. However it is legal to assign a static address from this range to the NetCom. Try to find an unused address in you network, starting at 169.254.0.1. Check by PING and ARP, if the address is used. If not, assign it to the NetCom.

This is only a workaround. The better solution is to install or configure a simple DHCP server program. Typical SOHO Internet routers of today already have such a server. Or you may change your network to static configuration.

9.1.4.OTHER CONFIGURATION

If the configuration of your computer differs from these examples, strong reasons are likely. Ask your network administrator for proper parameters in this situation.

10. HARDWARE DETAILS

So far many details of the hardware are not covered. The information is provided in this section.

10.1. SERIAL PORT

The serial ports in the NetCom Devices follow the specifications of RS 232. On some models it is also possible to use the serial port in RS 422 or RS 485 mode. This is defined by a set of DIP-switches. Here is a list of the available modes and the switch settings.

Warning: a bad configuration may cause serious damage in the NetCom or the connected device.











	Line Mode, Comment	S1	S2	S3	S4	Switch positions
RS232	Configuration via serial port ^{Note 1}	Off	Off	Off	Off	
	Data communication			On	On	
	Reload Factory values ^{Note 1}			Off	On	
RS422	Data communication Point-to-multipoint	Off	On	On	On	
RS485 by ART ^{Note 2}	4 wire Full Duplex	On	On	On	Off	
	2 wire Half Duplex with Echo			Off	On	
	2 wire Half Duplex without Echo			Off	Off	
RS485 by RTS	4 wire Full Duplex	On	Off	On	Off	
	2 wire Half Duplex with Echo			Off	On	
	2 wire Half Duplex without Echo			Off	Off	

Table 11: Switch Configuration of NetCom 113, 413, 813 and 813RM



	Line Mode, Comment	S1	S2	S3	S4	Switch positions
RS232	Configuration via serial port ^{Note 1}			Off	Off	
	Data communication	Off	Off	On	On	
	Reload Factory values ^{Note 1}			Off	On	

Table 12: Switch Configuration of NetCom 111, 411, 811 and 811RM



	Line Mode, Comment	S1	S2	Switch positions
RS232	Configuration via serial port ^{Note 1}	Off	Off	
	Data communication	On	On	
	Reload Factory values ^{Note 1}	Off	On	

Table 13: Switch Configuration of NetCom 211

Note 1: “Configuration via serial port” and “Reload Factory values” is only effective on port 1 of any NetCom Device.

Note 2: ART is the Automatic Receive Transmit control. In RS 485 this is the recommended option. The NetCom performs the required activation and disabling of the RS 485 transmitter by an internal automatic. It is available in NetCom 113, 413, 813 and 813RM models.

10.2. SIGNAL ASSIGNMENT

It is of course important to know the exact location of the serial signals in the configured mode. Here are the tables for the DB9 female connectors, as well as for the RJ45 and DB9 male connectors.

Pin	RS232	422/485 4wire	485 2wire	DB9 female
1	DCD	Rx- (A)		
2	TxD	Rx+ (B)		
3	RxD	Tx+ (B)	Data+ (B)	
4	DSR	Tx- (A)	Data- (A)	
5	GND	GND	GND	
6	DTR			
7	CTS			
8	RTS			
9	RI			

Table 14: Signal Assignment DB9 female

Pin RJ45	RS232	Pin DB9	RJ45 & DB9 male cable
1	RTS	7	
2	DTR	4	
3	GND	5	
4	TxD	3	
5	RxD	2	
6	DCD	1	
7	DSR	6	
8	CTS	8	

Table 15: Signal Assignment RJ45 and DB9 male cable

Please note the GND signal in RS 422 and RS 485 modes. This signal must also be connected between the serial devices. So in reality there is neither a 2-wire nor a 4-wire connection. With the exception of very special configurations, a serial cable without GND violates the specifications for RS 422 and RS 485.

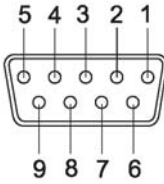
10.3. VIEWS OF NETCOM

This section will show all of the NetCom Devices provided by VScom.

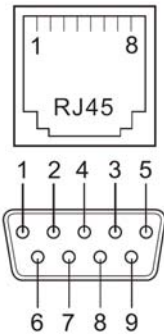
10.3.1. NETCOM 111, 113 AND 211



Image 109: NetCom-111 (113) Top and Front Side

Here showing NetCom 111 (the NetCom 113 is very similar) with the serial connector and the configuration switches. The hidden rear side holds the power connector, Reset hole and the Ethernet RJ45. Compare the view of NetCom 411 to see those components.



Image 110: NetCom-211 Top and Front Side

This is NetCom 211. Visible are the two RJ45 for COM1 and COM2 with the configuration DIP switch. The hidden rear side is the same as on NetCom 111/113 with Power connector, Reset and Ethernet RJ45.

10.3.2. NETCOM 411 AND 413



Image 111: NetCom 411/413 Top, Front and Rear Side

The front side of NetCom 413 and 411 holds the four DB9 female connectors for the serial ports. On the rear side are the power jack, the configuration switches (one switch on 411) and the Ethernet RJ45.

10.3.3. NETCOM 811 AND 813



Image 112: NetCom 811 and 813 Top, Front and Rear Side

The NetCom 811 and 813 provide 8 serial ports in two rows of four, equipped with DB9 female each. On the rear side are the power jack, the configuration switches (one switch on 811) and the Ethernet RJ45.

10.3.4. NETCOM 811RM AND 813RM RACKMOUNT



Image 113: NetCom 811RM and 813RM Top, Front and Rear Side

The NetCom 811RM and 813RM are designed for 19” Rackmount usage. They provide 8 serial ports in two rows of four, equipped with DB9 male each. To the left of the front is the Ethernet RJ45, the Reset hole is in the lower right corner. On the rear side are the power jack and the configuration switches (one switch on 811). Also provided is a mounting kit with two angles for a 19” rack.

11. TROUBLESHOOTING GUIDE

The most common problems when using NetCom are caused by a failure in the configuration of network parameters. This is a list of some symptoms, and tests to check them.

- 1) First examine the network configuration of your computer. Open a console window (MSDOS command prompt), and use the command `IPCONFIG /ALL` to retrieve the information. Among other information some data is displayed as this:
Ethernet adapter Local Area Connection:

```
Description.....: <Your LAN card>
Dhcp Enabled.....: Yes
Autoconfiguration Enabled....: Yes
IP Address.....: 192.168.1.154
Subnet Mask.....: 255.255.255.0
DHCP Server.....: 192.168.1.1
```

If DHCP is activated, and there is a DHCP server found, the configuration is OK. A common problem is an IP-Address like 169.254.xxx.yyy, because this is an automated address of APIPA. If no DHCP server is present in the network, a static configuration is recommended. Here we prefer the range of 192.168.1.1 up to 192.168.1.254 for computer and NetCom. Change the computers configuration, and select a similar address for NetCom.

- 2) Start the NetCom Manager program. Search for the device, the Manager performs a discovery of available NetCom devices. Check the properties of each device for a matching serial number. Once the NetCom is identified, check the IP-Address and the Netmask.

If all this information is displayed as Zero, the IP-settings do not match your computers settings. To correct this, you need administrative privileges for your computer. Start the NetCom Manager as Administrator, and configure correct parameters in the NetCom. Close the Manager program.

- 3) **Important:** The default configuration of NetCom may result in a fixed IP-Address. It will be the same for all connected devices. As a side effect the Manager can not send a dedicated configuration to a certain device. Therefore it is best to connect several NetCom one by one, configure them, connect the next and search for that device.
- 4) Try to PING the NetCom. Open a console window and use `PING <IP-Address of NetCom>` to send some data. The replies should reach your computer in a few milliseconds. If they time out, check the IP parameters again.
- 5) Telnet to the NetCom. Open a console window, and use the `Telnet <IP-Address of NetCom>` command to connect. The configuration menu appears. If not, open NetCom Manager, and check the setting of "Telnet port" in the NetCom. The default is the name "telnet", or the number 23.
- 6) Telnet to the serial port of NetCom. Open a console window, and use the `Telnet <IP-Address of NetCom> <data port>` command to connect. Everything you type is sent out through the serial port. Every data received is displayed on the screen. To check the operation, place a standard loopback plug to the serial port. Then you see your own data as an Echo while typing.
- 7) Check the Device Manager for error messages.
- 8) Run Hyperterminal, and open the serial port of NetCom device. Use the loopback plug to see the Echo of your typing. Use a Null Modem cable, and connect it from COM1 to the NetCom. Open a second Window of Hyperterminal for COM1. Send some data between these two windows. Transfer a file using ZMODEM protocol.
- 9) Often so-called Personal Firewall programs cause unspecific errors when other software starts communicating. Check the documentation of the program to see how to allow access.

Many other problems occur because of a failed serial connection, caused by wrong cabling. Here are some frequent causes.

- 10) The serial cable in RS 232 mode may simply be too long. This mostly happens with higher transmission rates.

- 11) The adapter provided with the NetCom Devices is not a simple Gender Changer. It is a Null-Modem adapter, and exchanges some signal positions. With the adapter the serial port is like a PC Com1, without it is like a Modem. Do not use this adapter when in RS 422 or RS 485.
- 12) In RS 422 and RS 485 it is mandatory to also connect the GND signal of all devices. It is a very frequent error not to do this. The information is transferred (and defined) by the positive or negative difference of the Data+ and Data- lines. However the specification requires a common voltage range between the connected devices. To ensure this range the connected GND is required.
- 13) A network in RS 485 requires biasing resistors. The Data+ line require a pull-up resistor to +5V, and the Data- line need a pull-down resistor to GND. The value is about 750 Ω to 1 k Ω . When no station is transmitting, the Data-lines float. This will cause noise and strange errors. The biasing resistors place a differential voltage to the lines, at least 200 mV. These resistors must not exist on the network more than once. Therefore they are not implemented in the NetCom serial ports.

12. GLOSSARY OF TERMS

- APIPA:** Automatic Private IP-Addressing
A scheme to self-assign an IP-Address to a network device. The device selects an address of the LINKLOCAL range 169.254.0.1 to 169.254.255.254 by random. If this address is unused, it assigns it to itself. Otherwise the next address is tested. It became widespread with Windows 98.
The netmask is 255.255.0.0, the addresses are not routed on the Internet.
- ART:** Automatic Receive Transmit control
Special control for RS485 modes. In RS485 the line driver for transmitting must be disabled (tri-stated) when the device does not send data. In a 2 wire configuration this is known as data direction change, with 4 wire it is called line contention.
- DHCP:** Dynamic Host Configuration Protocol
A service used to retrieve an IP-configuration from a database.
- FTP:** File Transfer Protocol
A common protocol to access a file server.
- HTTP:** HyperText Transfer Protocol
The protocol used by web browsers to access a web server.
- Internet:** The net connecting networks
A set of protocols to exchange data between different networks. These information's are carried via a global network of fibres and satellite links.
- IP:** Internet Protocol
The basic definitions for data packages. These Internet frames are stored and transported embedded in data frames of the local network.

- IP-Address:** Internet Address
The Internet address is noted as a group of 4 decimal numbers. Each station on the Internet has a unique address. Some ranges are reserved for private networks, not connected to the Internet.
- LINKLOCAL:**
This is a reserved address range for private (i.e. not connected to the Internet) networks. Designed for small number of stations. Used with APIPA.
- NAT:** Network Address Translation
A technique to have a private LAN share one public IP-Address. With NAT the transport information in IP-frames is exchanged by the public data of the NAT-Router.
- Netmask:** Groups stations to a Net
The AND-operation between the IP-Address and the Mask is an important value. When to stations have identical value here, they are “in the same net”. Which means they can communicate direct, without transmitting to a Router.
- PAT:** Port Address Translation
A technique to share a public IP-Address by many internal servers on private addresses. The target address and port is exchanged with values stored in an internal table. Mostly used together with NAT.
- Router:** Transmits data over the Internet
The backbone devices of the Internet. Routers connect two networks together. On one side they receive data frames containing IP-data. They extract these data, and send them on another side; there also stored in data frames of the second network. Typically they connect more than two networks. The basic task is to decide which route the IP-data must take now.

- RS-232/V.24: common serial transmission
Characters are sent as separate bits, timing is well defined. The medium is copper cable, using typical +/- 12 Volt. Each signal is defined related to a common ground; one wire per signal plus GND.
RS-232 is a point-to-point connection.
- RS-422: Industrial serial transmission (multidrop)
A transmission method with differential signals. Allows higher speed, longer cables and is resistive against electrical noise. RS-422 allows for up to 16 receivers. The transmission is via twisted pair copper cable using differential signals. Sender and receivers must share a common voltage range (max. +/-7Volt difference). Two lines per signal, plus common GND.
RS-422 is a point-to-multipoint connection.
- RS-485: Industrial serial transmission (multipoint)
The signals and cables are the same as RS-422. The transmitters can go tri-state. Several stations can send data on the same lines, at different times.
RS-485 is a multipoint-to-multipoint connection.
- SNMP: Simple Network Management Protocol
A general purpose configuration system. Devices understanding SNMP may be configured and monitored.
- TCP/IP: Transmission Control Program/Internet Protocol
TCP establishes connections between two partners via the Internet. The data is sent in IP-frames, each frame is acknowledged by the recipient. Lost packages are repeated.
Software using TCP has a secured transmission; the delivery of the data is guaranteed.
- UDP: User datagram protocol
Similar to TCP the data is sent in IP-frames. But in opposite there is no connection or acknowledge by the recipient. The transmission is faster for small data, but data can get lost.
Software using UDP must handle the related problems.

